

The SDA Handbook

Raife Smith II, Ph.D.

The SDA Handbook

R. F. Smith

© Copyright 2011 by R. F. Smith
© Copyright 2011 Polk Audio, Inc.

All rights reserved

Acknowledgements

I would like to thank Ken Swauger, former Polk Audio Customer Service Manager, and Kim Jasper, current Polk Audio Customer Service Manager, for their patient assistance with historical and technical information.

Polk Audio®, The Speaker Specialists®, Stereo Dimensional Array®, are trademarks of Britannia Investment Corporation used under license by Polk Audio Incorporated.

Table of Contents

Chapter 1 Introduction and Overview	1
1.1. Introduction	1
1.2. SDA Conceptualization	1
1.3. Why Were SDA's Discontinued?	2
1.4. The Beginning Of Polk Audio	3
Chapter 2 SDA Specifications by Generation	4
2.1. First Generation Specifications	4
2.2. Second Generation Specifications	5
2.3. Third Generation Specifications	6
2.4. Fourth Generation Specifications	8
2.5. Fifth Generation Specifications	10
Chapter 3 SDA Photo Gallery	13
First Generation Photographs	13
Second Generation Photographs	14
Third Generation Photographs	16
Fourth Generation Photographs	17
Fifth Generation Photographs	20
Chapter 4 SDA Buyers Guide: Physical Descriptions, Setup, Amplification, Testing and Shipping	23
4.1. Introduction	23
4.2. SDA SRS Series Versions	24
4.3. SDA Series Versions	26
4.4. Shipping Considerations	29
4.5. SDA Reviews	29
4.6. Room Placement	30
4.7. Amplification	30
4.8. Used Market Prices For SDA's	32
4.9. Quick Tests to Determine Proper Functioning	32
Chapter 5 New SDA Tweeters!	39
Chapter 6 SDA Modifications	44
6.1. Introduction	44
6.2. Recommended Modifications	44
6.2.1. SDA Inductors	46
6.3. Modification Benefits	48
6.4. Modification Costs	49
6.5. Custom AI-1 Non-Common Ground Amplifier Interface	49

6.6. Standard AI-1 Non-Common Ground Amplifier Interface Fabrication	50
6.7. High Current AI-1 Non-Common Ground Amplifier Interface	52
References	54
Appendix 1 SDA Technology Technical Paper	55
Appendix 2 SL3000 Tweeter Technical Paper	65
Appendix 3 SDA Schematics And Wiring Diagrams	70
Errata – SDA Compendium 2 nd Edition	98

List of Tables

Table 2.1. First Generation SDA Specifications	4
Table 2.2. Second Generation SDA Specifications	5
Table 2.3. Third Generation SDA Specifications	6
Table 2.4. Fourth Generation SDA Specifications	8
Table 2.5. Fifth Generation SDA Specifications	10
Table 2.6. SDA Series Replacement Parts	11
Table 4.1. AI-1 Amplifier Interface Compatibility Chart	31
Table 4.2. Proper Resistance Values	34
Table 4.3. SDA Wiring Checkpoints	35
Table 4.4. SDA Wiring Checkpoints	36
Table 4.5. SDA Wiring Checkpoints	37
Table 6.1 Specific SDA Modification Benefits	48

List of Figures

Figure 3.1. SDA1 And SDA 2	13
Figure 3.2. SDA SRS, SDA 1A, SDA 2, SDA CRS	14
Figure 3.3. SDA SRS	15
Figure 3.4. SDA SRS, SDA SRS 2, SDA 1, SDA 2A, SDA CRS+	16
Figure 3.5. SDA SRS 1.2, SDA SRS 2.3	17
Figure 3.6. SDA SRS 2.3 Donut Driver	18
Figure 3.7. SDA 1C	18
Figure 3.8. SDA 2B	19
Figure 3.9. SDA CRS+	19
Figure 3.10. SDA CRS+ Original Metal Stands	20
Figure 3.11. SDA SRS 1.2TL, SDA SRS 2.3TL, SDA SRS 3.1TL	20
Figure 3.12. SDA SRS 1.2TL, SDA SRS 2.3TL, SDA SRS 3.1TL	21
Figure 3.13. SDA SRS 1.2TL With RD0198-1 Tweeters	22
Figure 5.1. Front View Of RD0194-1 Tweeter	40
Figure 5.2. Rear View Of RD0194-1 Tweeter	40
Figure 5.3. Front View Of RD0198-1 Tweeter	41
Figure 5.4. Rear View Of RD0198-1 Tweeter	41
Figure 5.5. Front View Of SL2000 Tweeter	42
Figure 5.6. Rear View Of SL2000 Tweeter	42
Figure 5.7. Front View Of SL3000 Tweeter	43
Figure 5.8. Rear View Of SL3000 Tweeter	43
Figure 6.1. Transformer Orientation Diagram	50

Chapter 1

Introduction and Overview

1.1 Introduction

Polk Audio's Stereo Dimensional Array (SDA) loudspeakers present a deep, solid, and expansive soundstage and stereo image due to the cancellation of interaural crosstalk. Interaural crosstalk occurs when time delayed sound emanating from the left speaker is heard by the right ear and vice versa. Passive circuitry in the crossover network cancels these time delayed sounds by feeding an out of phase signal to the opposite speaker. An in-depth technical explanation of SDA technology is contained in Appendix 1.

This handbook contains basic information on the SDA series which was commercially available from 1982 to 1991. The SRT (Signature Reference Theater) and other Polk Audio loudspeakers which incorporated SDA after the discontinuance of the SDA series are not discussed in this text.

1.2 SDA Conceptualization

During a live Internet chat session on December 4, 2000, Polk Audio co-founder and CEO Matthew Polk discussed how he came up with the idea for SDA loudspeakers:

"I had just met Amy (whom I would later marry). Things moved pretty quickly and she invited me to go scuba diving in Cozumel (an island off the East coast of Mexico). I said, sure, that'd be great. Only problem was I'd never been scuba diving and didn't have the required courses, check-out dives, certifications, etc., etc., which usually take about 9 months. Amy said she knew an instructor who'd get me certified in 72 hours! So, I figure this is a test to see how adventurous I am and just like that, I'm off to Cozumel.

Well, learning how to scuba seems to be mostly about all the possible ways you can die underwater so when the day comes for your first dive you are legitimately terrified. You also have good reasons. You're standing at the end of pier over deep water wearing 50lbs of steel, lead and rubber. A guy is telling you in Spanglish to just breath normally once you hit the water and whatever you do, Don't Hold Your Breath! He says everything will be fine. You don't believe him.

Whether I jumped, tripped or was pushed, I don't know, but I find myself sinking into the water knowing that none of this stuff is going to work and that I am going to die. I am also holding my breath. I am sure my first breath will confirm my worst fears. Finally, I gave it a try. To my intense joy and amazement my lungs do not fill with water. I am breathing, under water!!

At times like this your senses become hyperaware. The first thing I noticed was the sound of my own breathing, loudly, very loudly. Then, I noticed that sound underwater seemed to come from everywhere. I was puzzled. Why can't I locate the directions of sounds underwater? After the dive, that was the thought that stayed with me. Why would it be impossible to localize sound underwater? The reason is that the speed of sound is much faster underwater. Our brains use the relative arrival time of sound at one ear vs. the other to tell us where the sound came from. Change the speed of sound and the brain's computations don't work anymore. From this experience I realized that it might be possible to use the same principles to trick the brain into believing that a pair of loudspeakers had sonically disappeared. We filed the first SDA patent 30 days later."

1.3 Why Were SDA's Discontinued?

Matthew Polk discusses the factors that lead to the discontinuance of the SDA series:

"This is a surprisingly difficult question to answer mainly because there is no simple answer. We began selling the SDA products in 1982 and stopped making them around 1990 except for a brief revival with the SRT system made in 1995 and 1996. From the first SDA-1 shown at CES in June 1982 customers loved them. However, this was not necessarily true of the retailers. SDA was a radical departure from the traditional audiophile concept of how audio should be reproduced and many of the salespeople in stores at that time were audiophiles. As a result, many of them hated SDA and steered customers away from them. In addition, because of the way SDA speakers work many retailers did not get them set up properly for demonstration which didn't help either. In spite of this SDA products sold amazingly well particularly when you consider how expensive they were relative to most everything else on the market. As I recall the original SDA-1 started out at \$1,600 per pair retail at a time when most stores had nothing over \$1,000 per pair. But, anyone who actually got to hear them was absolutely blown away and we were able to get a few good reviews particularly from Michael Riggs at High-Fidelity who described SDA as "Mind-boggling, astounding!". By 1986 we had a full line of SDA products from the SDA CRS+ at under \$1,000 to the SRS-1.2 at \$3,500.

But, the industry was changing rapidly. First, the era of big speakers was coming to an end and non-hobbyist customers were starting to prefer the then new sub-sat systems and the then brand-new concept of in-wall speakers. SDA speakers were big. The classic side-by-side driver arrangement meant a wide front baffle for any SDA product just as the trend was going to narrow towers and smaller speakers in general. Second, the small independent retailers were gradually turning into large regional chains with huge open format stores and non-hobbyist salespeople. The result of this was that retailers began to lose the ability to really demonstrate the performance of audio products. It's really impossible to describe the experience of SDA to someone. It really has to be demonstrated. So, as the stores became less and less able to demonstrate high performance products customers didn't have an opportunity to experience what SDA could deliver.

Third, the development of digital electronics and surround sound drove the cost of high quality audio components rapidly upward but drove the cost of low quality surround sound receivers rapidly downward with a commensurate reduction in performance. Because of the channel cross coupling in SDA it is always a difficult load for an amp to drive. Many of the new multi-channel receivers just couldn't do it. So, with fewer and more expensive high performance amps the options for good SDA electronics became very slim.

So, a combination of changes in what non-hobbyist customers wanted and what the retailers were capable of selling plus changing technology made the SDA products much more difficult to sell. Of course it had nothing to do with the performance of the SDA systems which continues astonish people even today.”

1.4 The Beginning Of Polk Audio, Inc.

Matthew Polk discusses the origin of Polk Audio:

“Some parts of the story of starting Polk Audio are best left untold. But, I suppose I can go a little beyond the official sanitized versions. I got my undergrad degree in Physics from Johns Hopkins in 1971 and continued there as a grad student in Marine Biology (don't ask!). The problem was that I hated Marine Biology and, as a result, was not a particularly diligent student. Frankly I was a lot more interested in building speakers for friends and trading them for derelict motorcycles which I would fix-up and drive until they broke. My buddy, George Klopfer, graduated the same time with a degree in History. He went back home to New Jersey and returned to Baltimore when his parents threw him out and after getting fired from about 6 jobs in a row. We were renting a dilapidated 200 year old cottage wondering what we were going to do with our lives when some friends came to us for advice on a sound system for their bluegrass conventions. George and I offered to build it for them.

To continue, we had about \$200 between us, enough for some materials, but no woodshop or anything else to produce the large cabinets required for a big outdoor system. So, we signed up for an adult education course in woodworking at the Hereford Community College, cost \$2 each. After patiently waiting through the teachers explanations (this is a table saw. It can cut your hand off, etc. etc.), we rolled our borrowed step van up and started running 4x8 sheets of plywood thought the saws, literally shoving people aside with their birdhouse or cake plate projects. After a while the teacher came over and asked, "You boys aren't doin' commercial work here are you?". We were invited not to come back but we got everything cut and managed to assemble everything in our 200 year old unheated, one buggy garage. Our friends were delighted with the system. Only problem, they had no money to pay for it. So, we became partners in the system and put the "Polk Audio" name on all the cabinets. These were the first.”

Chapter 2

SDA Specifications by Generation

Polk Audio Manufactured the SDA series loudspeakers from 1982 to 1991. The series underwent several changes in drivers and driver configurations, new model additions, crossover network configurations, and cabinet designs. There was never a radical sonic change from one generation to the next, just small to moderate performance and cosmetic enhancements.

The first generation SDA's used external fuses to protect the tweeters. The removable grille panel consisted of knit fabric stretched over a ½" thick anti-diffraction bezel. This generation of SDA's used the blade/blade interconnect cable (two flat blades at each end of the cable). Both blades carried a signal. Some of the earliest SDA 1's used a 3-pin interconnect cable similar to the one used on the RTA-12 speaker.

2.1 First Generation: SDA 1 and SDA 2

Table 2.1. First Generation SDA Specifications

	SDA 1	SDA 2
Driver Complement	Two 1 inch SL1000 silver coil dome tweeters Four 6-1/2 inch tri-laminate polymer bass-midrange drivers One 12 inch fluid-coupled subwoofer	Two 1 inch SL1000 or SL2000 silver coil dome tweeters Three 6-1/2 inch tri-laminate polymer bass-midrange drivers One 12 inch fluid-coupled subwoofer
Size (inches)	43-1/2H x 16W x 12D	39-1/2H x 16W x 12D
Weight Per Cabinet	85 pounds	80 pounds
Frequency Response	15 Hz to 26,000 Hz	16 Hz to 26,000 Hz
Recommended Amplification	10-500 watts/channel	10-500 watts/channel
Crossover Frequency	50 Hz, 125 Hz, and 2500 Hz	50 Hz and 2500 Hz
Nominal Impedance	4 ohms	4 ohms
Maximum Output Level	120 dB	118 dB
Efficiency	95 dB	92 dB
Price	\$850 each	\$625 each
Dates Of Manufacture	1982 to 1983	1982 to 1985

2.2 Second Generation: SDA SRS , SDA 1A, SDA 2, and SDA CRS

Table 2.2. Second Generation SDA Specifications

	SDA SRS	SDA 1A
Driver Complement	Four 1 inch SL2000 silver coil dome tweeters Eight 6-1/2 inch tri-laminate polymer bass-midrange drivers One 15 inch fluid-coupled subwoofer	Two 1 inch SL2000 silver coil dome tweeters Four 6-1/2 inch tri-laminate polymer bass-midrange drivers One 12 inch fluid-coupled subwoofer
Size (inches)	63-1/2H x 21W x 13D	43-1/2H x 16W x 12D
Weight Per Cabinet	182 pounds	85 pounds
Frequency Response	10 Hz to 26,000 Hz	15 Hz to 26,000 Hz
Recommended Amplification	10-1000 watts/channel	10-500 watts/channel
Crossover Frequency	45 Hz and 2000 Hz	50 Hz, 125 Hz, and 2500 Hz
Nominal Impedance	4 ohms	4 ohms
Maximum Output Level	125 dB	120 dB
Efficiency	93 dB	95 dB
Price	\$1295 each	\$875 each
Dates Of Manufacture	1985 to 1987	1983 to 1986

	SDA 2	SDA CRS
Driver Complement	Two 1 inch SL2000 silver coil dome tweeters Three 6-1/2 inch tri-laminate polymer bass-midrange drivers One 12 inch fluid-coupled subwoofer	Two 1 inch SL1000 or SL2000 silver coil dome tweeters Two 6-1/2 inch tri-laminate polymer bass-midrange drivers One 10 inch fluid-coupled subwoofer
Size (inches)	39-1/2H x 16W x 12D	12-1/2H x 20W x 9-1/2D
Weight Per Cabinet	80 pounds	38 pounds
Frequency Response	16 Hz to 26,000 Hz	31 Hz to 26,000 Hz
Recommended Amplification	10-500 watts/channel	10-200 watts/channel
Crossover Frequency	50 Hz and 2500 Hz	100 Hz and 3000 Hz
Nominal Impedance	4 ohms	6 ohms
Maximum Output Level	118 dB	116 dB
Efficiency	92 dB	92 dB
Price	\$625 each	\$395 each, Stands \$200/pair
Dates Of Manufacture	1982 to 1985	1984 to 1986

Second generation SDA's used an internal fast acting self-resetting semiconductor device to protect the tweeters rather than an external fuse. The removable grille panel consisted of knit fabric stretched over a thick (1/2" to 3/4" depending on model) anti-diffraction bezel. Two new models were introduced: the SDA CRS (Compact Reference System) in 1984 and the SDA SRS (Signature Reference System) in 1985. SRS speakers carried a badge with Matthew Polk's signature. This generation of SDA's used the blade/blade interconnect cable.

2.3 Third Generation: SDA SRS, SDA SRS 2, SDA 1B, SDA 2, and SDA CRS+

The third generation of SDA's included the introduction of the SDA SRS 2 in July of 1986. The SDA 1A was upgraded to the SDA 1B, the SDA 2 was upgraded to the SDA 2A, and the SDA CRS was upgraded to the SDA CRS+. The dimensional driver array, which had extended into the treble region on first and second generation SDA's, was restricted to the midrange region in third generation SDA's. Hence, the 1986 model SDA CRS+ and SDA 2A only had one tweeter and the horizontal tweeter arrangement of the SDA 1A was changed to a vertical (progressive point source) arrangement in the SDA 1B. The SDA's also received crossover network and driver changes. This generation of SDA's used the blade/blade interconnect cable. The removable grille panel consisted of knit fabric stretched over a thick (1/2" to 3/4" depending on model) anti-diffraction bezel.

Table 2.3. Third Generation SDA Specifications

	SDA SRS	SDA SRS 2
Driver Complement	Four 1 inch SL2000 silver coil dome tweeters Eight 6-1/2 inch tri-laminate polymer bass-midrange drivers One 15 inch fluid-coupled subwoofer	Two 1 inch SL2000 silver coil dome tweeters Four 6-1/2 inch tri-laminate polymer bass-midrange drivers One 15 inch fluid-coupled subwoofer
Size (inches)	63-1/2H x 21W x 13D	50H x 20-11/16W x 12-11/32D
Weight Per Cabinet	182 pounds	142 pounds
Frequency Response	10 Hz to 26,000 Hz	12 Hz to 26,000 Hz
Recommended Amplification	10-1000 watts/channel	10-750 watts/channel
Crossover Frequency	45 Hz and 2000 Hz	45 Hz and 2000 Hz
Nominal Impedance	4 ohms	4 ohms
Maximum Output Level	125 dB	123 dB
Efficiency	93 dB	92 dB
Price	\$1495 each	\$995 each
Dates Of Manufacture	1985 to 1987	1986 to 1987

	SDA 1B	SDA 2A
Driver Complement	Two 1 inch SL2000 silver coil dome tweeters Four 6-1/2 inch tri-laminate polymer bass-midrange drivers One 12 inch fluid-coupled subwoofer	One 1 inch SL2000 silver coil dome tweeter Two 6-1/2 inch tri-laminate polymer bass-midrange drivers One 12 inch fluid-coupled subwoofer
Size (inches)	43-1/2H x 16W x 12D	39-1/2H x 16W x 12D
Weight Per Cabinet	85 pounds	65 pounds
Frequency Response	14 Hz to 26,000 Hz	15 Hz to 26,000 Hz
Recommended Amplification	10-500 watts/channel	10-500 watts/channel
Crossover Frequency	50 Hz and 2000 Hz	50 Hz and 2000 Hz
Nominal Impedance	4 ohms	4 ohms
Maximum Output Level	122 dB	120 dB
Efficiency	92 dB	92 dB
Price	\$700 each	\$500 each
Dates Of Manufacture	1986 to 1987	1985 to 1987

	SDA CRS+
Driver Complement	One 1 inch SL2000 silver coil dome tweeters Two 6-1/2 inch tri-laminate polymer bass-midrange drivers One 10 inch fluid-coupled subwoofer
Size (inches)	12-1/2H x 20W x 9-1/2D
Weight Per Cabinet	36 pounds
Frequency Response	24 Hz to 26,000 Hz
Recommended Amplification	10-200 watts/channel
Crossover Frequency	60 Hz and 2000 Hz
Nominal Impedance	6 ohms
Maximum Output Level	117 dB
Efficiency	92 dB
Price	\$400 each, Stands \$200/pair
Dates Of Manufacture	1986 to 1987

2.4 Fourth Generation: SDA SRS 1.2, SDA SRS 2.3, SDA SRS 2, SDA 1C, SDA 2B, SDA CRS+

SDA's of this generation, with the exception of the very rare SDA SRS 2, are the ones most commonly seen on the used market. The SDA SRS was upgraded to the SDA SRS 1.2. The SDA SRS 2 was improved and carried over to the fourth generation and was produced from 1987 to 1988. It co-existed for a time with the similarly sized SDA 2.3. The SDA 1B was upgraded to the SDA 1C, and the SDA 2A was upgraded to the SDA 2B.

All tower SDA's received new cabinets with stronger internal bracing to reduce resonance, new crossover networks, driver changes, and (except for the SDA SRS 2) new, more contemporary cabinet cosmetics. The removable grille panel consisted of knit fabric stretched over a thick (1/2" to 3/4" depending on model) anti-diffraction bezel. The impedance was raised to 6 ohms to provide a more stable amplifier load. The SDA CRS+ did not receive a new cabinet design or a new version number, although it did receive crossover network and driver changes. Fourth generation SDA's used the pin/blade interconnect cable. The pin carried a signal while the blade did not.

Table 2.4. Fourth Generation SDA Specifications

	SDA SRS 1.2	SDA SRS 2.3
Driver Complement	Four 1 inch SL2000 silver coil dome tweeters Eight 6-1/2 inch tri-laminate polymer bass-midrange drivers One 15 inch fluid-coupled subwoofer	Three 1 inch SL2000 silver coil dome tweeters Six 6-1/2 inch tri-laminate polymer bass-midrange drivers One 15 inch fluid-coupled subwoofer
Size (inches)	63-1/2H x 21W x 13-1/8D	55H x 20-11/16W x 13-1/8D
Weight Per Cabinet	180 pounds	155 pounds
Frequency Response	10 Hz to 26,000 Hz	12 Hz to 26,000 Hz
-3 dB Frequency Limits	27 Hz to 20,000 Hz	30 Hz to 20,000 Hz
Recommended Amplification	50-1000 watts/channel	50-750 watts/channel
Nominal Impedance	6 ohms	6 ohms
Efficiency	91 dB	91 dB
Price	\$1500 each	\$1100 each
Dates Of Manufacture	1987 to 1988	1987 to 1988

	SDA SRS 2	SDA 1C
Driver Complement	Two 1 inch SL2000 silver coil dome tweeters Four 6-1/2 inch tri-laminate polymer bass-midrange drivers One 15 inch fluid-coupled subwoofer	Two 1 inch SL2000 silver coil dome tweeters Four 6-1/2 inch tri-laminate polymer bass-midrange drivers One 12 inch fluid-coupled subwoofer
Size (inches)	50H x 20-11/16W x 12-11/32D	44H x 15-7/8W x 11-1/2D 43H x 16-9/16W x 11-1/2D-Studio Version
Weight Per Cabinet	142 pounds	100 pounds, Studio Version 85 pounds
Frequency Response	12 Hz to 26,000 Hz	15 Hz to 26,000 Hz
-3 dB Frequency Limits	Not Specified	35 Hz to 20,000 Hz
Recommended Amplification	10-750 watts/channel	50-500 watts/channel
Crossover Frequency	45 Hz and 2000 Hz	50 Hz and 2000 Hz
Nominal Impedance	6 ohms	6 ohms
Maximum Output Level	123 dB	Not Specified
Efficiency	92 dB	90 dB
Price	\$995 each	\$800-900 each, Studio Version \$700 each
Dates Of Manufacture	1987 to 1988	1987 to 1990

	SDA 2B	SDA CRS+
Driver Complement	One 1 inch SL2000 silver coil dome tweeters Two 6-1/2 inch tri-laminate polymer bass-midrange drivers One 12 inch fluid-coupled subwoofer	One 1 inch SL2000 silver coil dome tweeters Two 6-1/2 inch tri-laminate polymer bass-midrange drivers One 10 inch fluid-coupled subwoofer
Size (inches)	39-5/8H x 16-6/16W x 11-1/2D 38-1/2H x 15-7/8W x 11-1/2D-Studio Version	12-3/4H x 20W x 10-1/8D
Weight Per Cabinet	80 pounds, Studio Version 65 pounds	35 pounds
Frequency Response	15 Hz to 26,000 Hz	25 Hz to 26,000 Hz
-3 dB Frequency Limits	38 Hz to 20,000 Hz	42 Hz to 20,000 Hz
Recommended Amplification	30-350 watts/channel	30-200 watts/channel
Crossover Frequency	Not Specified	Not Specified
Nominal Impedance	6 ohms	6 ohms
Maximum Output Level	Not Specified	Not Specified
Efficiency	89.7 dB	89.5 dB

2.5 Fifth Generation: SDA SRS 1.2TL, SDA SRS 2.3TL, and SDA 3.1TL

The fifth generation brought the addition of a new model, the SDA SRS 3.1TL. The SDA SRS 1.2 was upgraded to the SDA SRS 1.2TL. The SDA SRS 2.3 was upgraded to the SDA SRS 2.3TL. A “TL” version of the 1989 CRS+ was planned, but the SDA series was discontinued before it went into production. There is a schematic diagram for converting a CRS+ to a “CRS+TL” in Appendix 3. The impedance of the SRS series was raised to be “compatible with 8 ohm outputs” in order to provide a more stable amplifier load. The removable grille panel consisted of knit fabric stretched over a thick (1/2” to 3/4” depending on model) anti-diffraction bezel. Fifth generation SDA’s used the pin/blade interconnect cable.

The most significant change of the fifth generation SDA’s was the addition of the new SL 3000 tweeter. The SL 1000 and SL 2000 tweeters used in earlier generations of SDA loudspeakers had a 5 dB resonance peak at 13,000 Hz. Although this resonance peak was not objectionable to most listeners, it did add a bit of brightness to the sound (which some listeners preferred). The SL 3000 tweeter corrected the resonance problem. Although the TL series speakers provided the most flat, most extended, and most accurate frequency response of any SDA speaker to date, some listeners thought that they sounded “dull” in comparison to the previous SRS speakers with the SL2000 tweeter.

Table 2.5. Fifth Generation SDA Specifications

	SDA SRS 1.2TL	SDA SRS 2.3TL
Driver Complement	Four 1 inch SL3000 silver coil dome tweeters Eight 6-1/2 inch tri-laminate polymer bass-midrange drivers One 15 inch fluid-coupled subwoofer	Three 1 inch SL3000 silver coil dome tweeters Six 6-1/2 inch tri-laminate polymer bass-midrange drivers One 15 inch fluid-coupled subwoofer
Size (inches)	63-1/2H x 21-3/4W x 13-1/8D	55H x 20-5/8W x 13-1/8D
Weight Per Cabinet	180 pounds	155 pounds
Frequency Response	10 Hz to 26,000 Hz	12 Hz to 26,000 Hz
-3 dB Frequency Limits	27 Hz to 25,000 Hz	30 Hz to 25,000 Hz
Recommended Amplification	50-1000 watts/channel	50-750 watts/channel
Nominal Impedance	Compatible with 8 ohm outputs	Compatible with 8 ohm outputs
Efficiency	91 dB	90 dB
Price	\$1700 each	\$1250 each
Dates Of Manufacture	1989 to 1991	1989 to 1991

	SDA SRS 3.1TL
Driver Complement	One 1 inch SL3000 silver coil dome tweeter Five 6-1/2 inch tri-laminate polymer bass-midrange drivers One 12 inch fluid-coupled subwoofer
Size (inches)	48H x 15-3/4W x 13-1/8D
Weight Per Cabinet	101 pounds
Frequency Response	15 Hz to 26,000 Hz
-3 dB Frequency Limits	32 Hz to 25,000 Hz
Recommended Amplification	50-500 watts/channel
Nominal Impedance	Compatible with 8 ohm outputs
Efficiency	90 dB
Price	\$1000 each
Dates Of Manufacture	1989 to 1991

Table 2.6. SDA Series Replacement Parts

MODEL	TWEETER	DRIVER	SDA DRIVER	BASS RADIATOR	CROSSOVER
SDA SRS 1.2TL	4x SL3000	4x MW6503	4x MW6511	SW150	BE2000-C
SDA SRS 1.2	4x SL2000	4x MW6503	4x MW6511	SW150	BE2000-B
SDA SRS	4x SL2000	4x MW6503	4x MW6503	SW150	BE2000-A
SDA SRS 2.3TL	3x SL3000	4x MW6510	2x MW6510	SW155	BR2200-C
SDA SRS 2.3	3x SL2000	2x MW6511 2x MW6513	2x MW6510	SW155	BE2200-A
SRS2 PIN/BLADE SDA CONNECTOR	2x SL2000	2x MW6511	2x MW6510	SW155	Not Specified
SRS2 TWIN-BLADE SDA CONNECTOR	2x SL2000	2x MW6509	2x MW6509	SW150	Not Specified
SRS 3.1TL	SL3000	4x MW6503	MW6511	SW122	BE0031-B
SDA 1C	2x SL2000	2x MW6511	2x MW6510	SW120	BE1618-B
SDA 1B	2x SL2000	2x MW6509	2x MW6509	SW120	Not Specified
SDA 1A	2x SL2000	2x MW6501	2x MW6501	SW120	Not Specified
SDA 1	2x SL1000	2x MW6501	2x MW6501	SW120	Not Specified
SDA 2B	SL2000	MW6503	MW6511	SW121	BE1807-B
SDA 2A	SL2000	MW6510	MW6510	SW121	Not Specified
SDA 2	2x SL2000	2x MW6501	MW6501	SW120	Not Specified
CRS+ PIN/BLADE SDA CONNECTOR	SL2000	MW6510	MW6511	SW102	BE1807-B
CRS+ TWIN-BLADE SDA CONNECTOR	SL2000	MW6510	MW6510	SW100	Not Specified
SDA CRS	2x SL2000	MW6503	MW6503	SW102	Not Specified

Chapter 3

SDA Photo Gallery



SDA 1

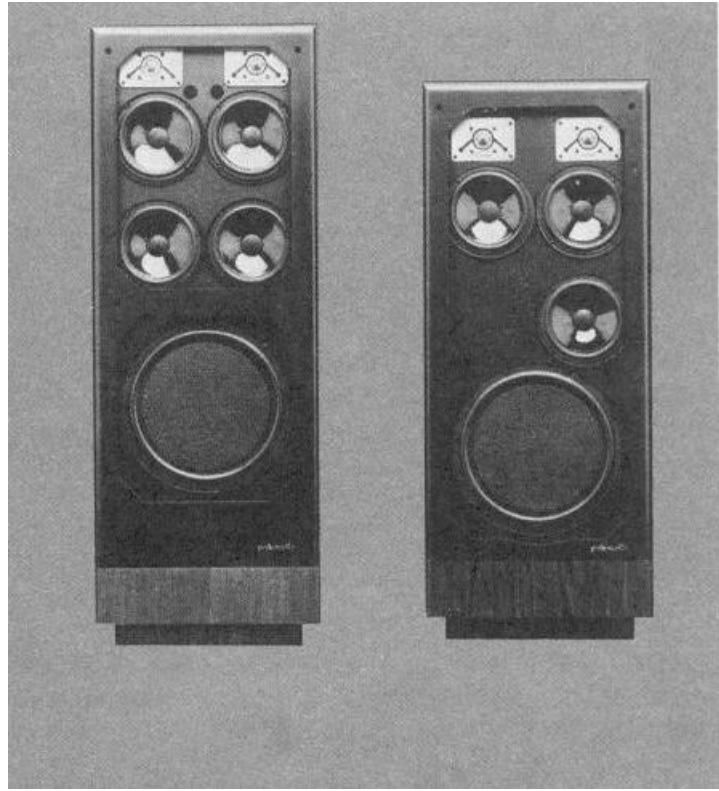

SDA1 and SDA 2

Figure 3.1. First Generation: SDA 1 and SDA 2.



Figure 3.2. Second Generation: SDA SRS, SDA 1A, SDA 2, SDA CRS.

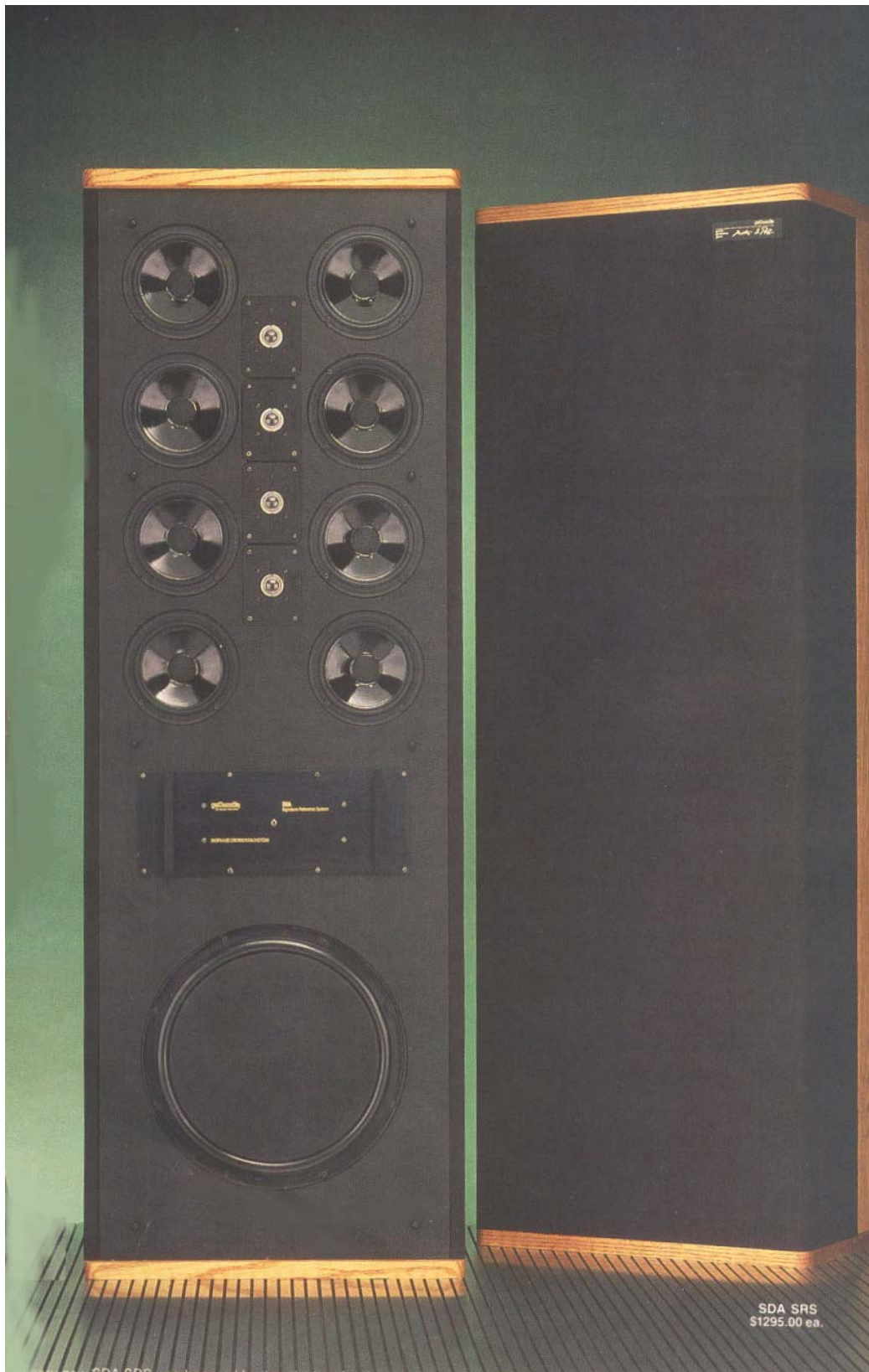

Figure 3.3. Second Generation: SDA SRS.



Figure 3.4. Third Generation: SDA SRS, SDA SRS 2, SDA 1B, SDA 2A, SDA CRS+.



Figure 3.5. Fourth Generation: SDA SRS 1.2, and right side SDA SRS 2.3.



Figure 3.6. Closeup of left side SDA 2.3 showing “donut” upper stereo driver. Some of the earliest 2.3’s had stereo drivers (MW6513) with extra mass added to improve sub-bass response. Only the upper and lower driver in the four drive line source array had the donut driver.



Figure 3.7. SDA 1C.



Figure 3.8. SDA 2B.



Figure 3.9. SDA CRS+.



Figure 3.10. Original Polk CRS stands, 25 inches tall by 14.5 inches wide. Spikes added another 1.5 inches of height.



Figure 3.11. Fifth Generation: Left side speakers from SDA SRS 1.2TL, SDA SRS 2.3TL, SDA 3.1TL. Note that the driver arrangement between the SDA 2.3 and SDA 2.3TL was reversed: 2.3 with four drivers along outside edges, 2.3TL with four drivers along inside edges.



Figure 3.12. Fifth Generation: SDA SRS 1.2TL, SDA SRS 2.3TL, SDA 3.1TL



Figure 3.13. Fifth Generation: SDA SRS 1.2TL with RD0198 tweeters.

Chapter 4

SDA Buyer's Guide: Physical Descriptions, Setup, Amplification, Testing and Shipping

4.1 Introduction

The good news is that finding a pair of SDA's is relatively easy. They show up fairly frequently on Audiogon.com, eBay and Craigslist. The bad news is that finding a pair in good to excellent to mint condition is often an exercise in frustration. This frustration is compounded by the existence of multiple versions within a particular model. Often, a seller is not absolutely sure which version is being offered for sale.

Fourth generation SDA's (SDA SRS 1.2, SDA SRS 2.3, SDA 1C, SDA 2B, SDA CRS+) are the models that show up most frequently on the used market. First, second, third, and fifth generation SDA's **in good condition** are so rare as to almost be non-existent. When a pair of SDA loudspeakers does appear on the used market, it is due to one of four reasons:

1. They've been beat to Hell and back.
2. The owner is moving to smaller quarters and will not have room for them.
3. The owner says they really don't sound any better than "regular" speakers.
4. The dreaded WAF (wife acceptance factor) was in full effect.

Number 3 above is usually due to the owner running the speakers with an under-powered receiver (20 to 50 watts typical). The recommended minimum amplification is 200 watts of high current power per channel to make SDAs "wake up" and sing. The original SDA SRS was reviewed in the November 1985 issue of Stereo Review magazine. Here is what reviewer Julian Hirsch had to say:

"To Get the most out of the Polk SDA-SRS speakers, we would recommend using an amplifier capable of delivering at least 200 watts per channel into 4-ohm loads. With that kind of reserve power you'll be able, at least once in a while, to "open up" the system and enjoy!"

Even with the smallest of SDA's (the CRS+'s), I prefer 200 watts minimum. Be advised that higher power is not about the ability to play loud. It is about the ability to play with greater clarity and better stereophonic imaging at reasonable listening levels.

All SDA's were sealed box designs with passive radiators. I once saw an ad for a pair of SDA's in which the owner had drilled a *port* to "improve the bass response considerable [sic]". I have seen a couple of ads in which the passive radiator was replaced with an *active*

woofer. If you ever encounter a pair of SDA's with drilled ports and/or an active woofer in place of the passive radiator...**RUN!!**

There were twenty-one models/versions of SDA loudspeakers manufactured between the debut of the SDA 1 in 1982 and the end of production of the SDA series in 1991: 1. SDA SRS, 2. SDA SRS 1.2, 3. SDA SRS 1.2TL, 4. SDA SRS 2 (blade/blade), 5. SDA SRS 2 (pin/blade), 6. SDA SRS 2.3, 7. SDA SRS 2.3TL, 8. SDA SRS 3.1TL, 9. SDA 1, 10. SDA 1A, 11. SDA 1B, 12. SDA 1C (blade/blade), 13. SDA 1C (pin/blade). 14. SDA 2, 15. SDA 2A, 16. SDA 2B (1987 blade/blade), 17. SDA 2B (1987 pin/blade), 18. SDA 2B (1989 pin/blade), 19. SDA CRS, 20. SDA CRS+ (blade/blade), 21. SDA CRS+ (1987 pin/blade), SDA CRS+ (1989 pin/blade).

Frequently, a seller will offer a pair of SDA's for sale without knowing for certain what version they have. Sometimes they think they know which version they have but they are unaware of the sometimes subtle changes from one version to the next. Compounding this difficulty is the fact that some owners have engaged in inappropriate "upgrades" by swapping out drivers and tweeters. Another aggravating factor is that Polk often did not use accurate version labels on the backs of their speakers. For example, the SDA 1 comes in four versions. The label on the back of each version often simply says "SDA 1". There is usually no "1A", "1B", or "1C" to denote the successive upgrade versions. This was due to Polk's practice of using up the leftover labels from a previous model version.

The following guidelines offer some assistance in figuring out exactly what you are attempting to buy or sell.

4.2 SDA Signature Reference System (SRS) Series Versions

SDA SRS

All three versions of the largest SRS speakers (SRS, SRS 1.2, and SRS 1.2TL) are the same approximate size and weight and look very similar. For the original SRS, the label on the rear near the serial number will read "SDA SRS". The SDA interconnect socket will have two horizontal slots for the interconnect cable blades. All eight of the bass-midrange drivers will have MW6503 stenciled on them. The metal panel in the lower center of the speaker is the crossover circuit board. There will be four bolts across the top, four bolts across the bottom and five bolts in the center. Some of the earlier SRS's had oak or walnut end caps made of laminated boards. Sometimes those end caps would crack along the laminated board seams. The cracks are easily repaired with wood filler and stain. The nominal impedance is 4 ohms.

SDA SRS 1.2

The label on the rear near the serial number will usually, but not always, read "SRS 1.2". Some of the earliest production runs of the SDA SRS 1.2 may only read "SDA SRS" on the serial number label. The SDA interconnect socket will have a round hole above a horizontal slot for the interconnect cable pin and blade. The four stereo bass-midrange drivers along the inside edge of the speaker will have MW6503 stenciled on them. The four SDA drivers along the outside edge of the speaker will have MW6511 stenciled on them. The metal

panel in the lower center of the speaker is the crossover circuit board. There will be four bolts across the top, four bolts across the bottom and five bolts in the center. The nominal impedance was raised from 4 to 6 ohms. Some people have “upgraded” their SDA SRS 1.2s to the “TL” model simply by replacing all of the SL2000 tweeters with SL3000 tweeters. The crossover networks between the 1.2 and 1.2TL versions are totally different and the SRS 1.2 will not provide optimum performance with switched tweeters. Furthermore, the lower impedance of the SL3000 tweeter could cause amplifier protection circuitry to trip. A technical report on the SL3000 tweeter is contained in Appendix 2.

SDA SRS 1.2TL

The label on the rear near the serial number will read “SRS 1.2” or “SRS 1.2TL”. The SDA interconnect socket will have a round hole above a horizontal slot for the interconnect cable pin and blade. The four stereo bass-midrange drivers along the inside edge of the speaker will have MW6503 stenciled on them. The four stereo drivers along the outside edge of the speaker will have MW6511 stenciled on them. The metal panel in the lower center of the speaker is the crossover circuit board. There will be four bolts across the top, four bolts across the bottom and one bolt in the center. However, I have run across a couple of examples of SRS 1.2TL’s which had the crossover plate bolt pattern of the SRS 1.2. I assume Polk wanted to use up left over parts from the earlier SRS 1.2 production run. The four SL3000 tweeters will have either a bronze-tinted, gold-tinted, or green-tinted metallic dome, in contrast to the silver-white plastic dome of the SL2000 tweeters used on the SDA SRS and SDA SRS 1.2. The nominal impedance was raised from 6 to “compatible with 8 ohms”, meaning it had the impedance characteristics of an 8 ohm speaker over much of its frequency response range.

SDA SRS 2

The 1986 version will have an SDA interconnect socket with two horizontal slots for the interconnect cable blades. All four bass-midrange drivers will have MW6509 stenciled on them. The label on the rear near the serial number will read “SRS 2”.

The 1987 version will have an SDA interconnect socket with a round hole above a horizontal slot for the interconnect cable pin and blade. The two SDA bass-midrange drivers along the outside edge of the speaker will have MW6510 stenciled on them. The two stereo drivers along the inside edge of the speaker will have MW6511 stenciled on them. The label on the rear near the serial number will read “SRS 2”.

SDA SRS 2.3

The label on the rear near the serial number will read “SRS 2.3”. The SDA interconnect socket will have a round hole above a horizontal slot for the interconnect cable pin and blade. There are two stereo drivers (MW6511) along the inside edges of the speakers. There are four drivers in a line source array along the outside edges of the speakers. The first and fourth drivers (MW6513) are stereo mid-bass drivers. The second and third drivers (MW6510) are the SDA dimensional drivers. Some of the earliest SRS 2.3’s had a flat disk

(“donut”) appended to the front of the first and fourth stereo driver in the line source array in order to improve bass performance.

As with the SDA SRS 1.2, some people have “upgraded” their SDA SRS 2.3’s to the “TL” model simply by replacing all of the SL2000 tweeters with SL3000 tweeters. The crossover networks between the 2.3 and 2.3TL versions are totally different and the SRS 2.3 will not provide optimum performance with switched tweeters. Furthermore, the lower impedance of the SL3000 tweeter could cause amplifier protection circuitry to trip.

SDA SRS 2.3TL

The label on the rear near the serial number will read “SRS 2.3” or “SRS 2.3TL”. The SDA interconnect socket will have a round hole above a horizontal slot for the interconnect cable pin and blade. The driver complement and driver arrangement is different from the SRS 2.3. Whereas the four driver line source array of the 2.3 was oriented along the outer edge of each speaker, the 2.3TL has the four driver line source array oriented along the inner edge of each speaker. The two SDA bass-midrange drivers near the outer edge of each speaker are MW6510’s. The four stereo drivers along the inside edge of the speaker are also MW6510’s. The nominal impedance was raised from 6 to “compatible with 8 ohms”, meaning it had the impedance characteristics of an 8 ohm speaker over much of its frequency response range.

SDA SRS 3.1TL

This newly introduced 5th generation model is one of the most rarely seen SDA’s. It is similar in size to the SDA 1C, but has the line source array driver array common to all SRS’s. It has a single SDA dimensional driver (MW6511) near the outside edge of the speakers and four mid-woofers (MW6503’s) and a single SL3000 tweeter in a line array near the inside edge of the speakers.

4.3 SDA Series Versions

SDA 1

The label on the rear near the serial number will read “SDA 1”. The SDA interconnect socket will have two horizontal slots for the twin blade interconnect cable. The binding post plate will have an external tweeter protection fuses. All four bass-midrange drivers will have MW6501 stenciled on them. The two tweeters will be horizontally oriented. Some of the earliest SDA 1’s used a three pin interconnect cable similar to the one used on the RTA-12 loudspeaker. The two holes between the tweeters and upper two drivers (refer to figure 3.1) are pressure vents to prevent buckling of the drivers when the speakers were driven hard. The upper two drivers were in isolated enclosures.

There was also a “Signature Edition” SDA 1 that had a brass plate with Matthew Polk’s signature covering the pressure vent holes and a modified crossover.

SDA 1A

The label on the rear near the serial number will read “SDA 1”. The SDA interconnect socket will have two horizontal slots for the twin blade interconnect cable. The binding post plate **will not** have an external tweeter protection fuse. All four bass-midrange drivers will have MW6501 stenciled on them. The two tweeters will be horizontally oriented.

SDA 1B

The cabinet exterior of the SDA 1B is identical to the SDA 1A. The label on the rear near the serial number will read “SDA 1”. The SDA interconnect socket will have two horizontal slots for the twin blade interconnect cable. The binding post plate **will not** have an external tweeter protection fuse. All four bass-midrange drivers will have MW6509 stenciled on them. The two tweeters will be **vertically** oriented. The crossover of the 1B version was modified to restrict the SDA effect to the midrange drivers. The two vertically arrayed tweeters act as a progressive point source.

SDA 1C

The cabinet exterior of most SDA 1C's differs substantially from the 1B. The label on the rear near the serial number will read “SDA 1”. The SDA interconnect socket will have a round hole above a horizontal slot for the pin/blade interconnect cable. Oak or walnut end caps cover the top and bottom of the speaker. The two SDA bass-midrange drivers will have MW6510 stenciled on them. The two stereo bass-midrange drivers will have MW6511 stenciled on them. The two tweeters will be vertically oriented. The crossover of the 1C version was modified provide an easier load for an amplifier. The nominal impedance was raised from 4 ohms to 6 ohms.

There was also a “studio” version cabinet that was clad in black vinyl that did not have wood end caps. Some of the first SDA 1C speakers used the same cabinet style as the SDA 1B. Some of the first SDA 1C's also used a blade/blade interconnect cable rather than a pin/blade cable.

SDA 2

The label on the rear near the serial number will read “SDA 2”. The SDA interconnect socket will have two horizontal slots for the twin blade interconnect cable. The binding post plate will have an external tweeter protection fuse. All three bass-midrange drivers will have MW6501 stenciled on them. The two tweeters will be horizontally oriented.

SDA 2A

The label on the rear near the serial number will read “SDA 2”. The SDA interconnect socket will have two horizontal slots for the twin blade interconnect cable. The binding post plate **will not** have an external tweeter protection fuse. This version only uses one stereo driver rather than two. Both the SDA and the stereo bass-midrange drivers will have MW6510 stenciled on them. The crossover of the 2A version was modified to restrict the

SDA effect to the midrange drivers. This version only has one tweeter that acts as a progressive point source.

SDA 2B

The cabinet exterior of the SDA 2B differs substantially from the 2A. Oak or walnut end caps cover the top and bottom of the speaker. There was also an alternate “studio” cabinet that was clad in black vinyl that did not have wood end caps. The label on the rear near the serial number will read “SDA 2”. The SDA bass-midrange driver will have MW6511 stenciled on it. The stereo bass-midrange driver will have MW6503 stenciled on it. This version only has one tweeter that acts as a progressive point source. The nominal impedance was raised from 4 ohms to 6 ohms.

There were three versions of the SDA 2B: the 1987 version that used a blade/blade interconnect, a 1987 version that used a pin/blade interconnect, and a 1989 version that used a pin/blade interconnect. The crossover circuits of the 1987 and 1989 versions are the same except for the improved tweeter protection polyswitch in the 1989 version. The 1987 and 1989 versions of the SDA 2B used the same crossover circuit as the 1987 and 1989 versions of the SDA CRS+.

SDA CRS

The label on the rear near the serial number will read “SDA CRS”. The SDA interconnect socket will have two horizontal slots for the twin blade interconnect cable. Both bass-midrange drivers will have MW6503 stenciled on them. The two tweeters will be horizontally oriented. This, and the subsequent CRS+ versions had the passive radiator mounted on the rear of the cabinet.

SDA CRS+ (1986 version)

The label on the rear near the serial number will read “SDA CRS”. The SDA interconnect socket will have two horizontal slots for the twin blade interconnect cable. Both the SDA and the stereo bass-midrange drivers will have MW6510 stenciled on them. The crossover of the CRS+ version was modified to restrict the SDA effect to the midrange drivers. This version only has one tweeter that acts as a progressive point source.

SDA CRS+ (1987 version)

The cabinet exterior of the 1987 version CRS+ is slightly larger than the 1986 version, though they are identical in appearance. The label on the rear near the serial number will read “SDA CRS”. The SDA interconnect socket will have a round hole above a horizontal slot for the pin/blade interconnect cable. The SDA bass-midrange driver will have MW6511 stenciled on it. The stereo bass-midrange driver will have MW6510 stenciled on it. This version only has one tweeter that acts as a progressive point source. This version of the SDA CRS+ uses the same crossover circuit as the 1987 version of the SDA 2B.

SDA CRS+ (1989 version)

This version is identical to the 1987 CRS+ except that the tweeter protection polyswitch was improved. This version of the SDA CRS+ uses the same crossover circuit as the 1989 version of the SDA 2B.

4.4 Shipping Considerations

When shipping any of the SDA CRS speakers, it is advised that the speaker be shipped lying on its back. This is because the binding post plate sits high near an upper rear corner of the speaker cabinet and has a very heavy inductor coil bolted to the other side of it. The crossover circuit board is attached to the top of this coil with flimsy plastic pins (“standoffs”). The inductor can get knocked loose during shipment and may rattle around inside the cabinet causing damage to the drivers and the crossover board. The coil wiring may also unravel.

If you find a pair of CRS’s that come with the original Polk metal stands, it is best to have the stands shipped in a separate container. Although both CRS speakers will fit neatly inside the stands, a hard bump during shipment can cause significant damage if the metal comes into contact with the wooden cabinet.

I have purchased three pairs of used SDA CRS+’s and each pair arrived with the crossover board/inductor coil knocked loose.

For any of the tower SDA’s, local pickup or local delivery is the best option, although the SDA SRS 3.1TL, all SDA 1 versions, and all SDA 2 versions are small enough to be carried by common carriers (UPS, FedEx, etc.). If you are going to ship the speakers, pack the speakers like they are going to war. I have had two pairs of extremely well packed SDA 1C’s and one pair of SDA 2B’s shipped to me by UPS with no damage.

For the larger SRS’s, truck shipping typically runs \$200 to \$500 depending on the carrier and the distance. Air freight is also an option. If you shop around you can find reasonable shipping rates and sometimes discounted rates. Please be aware that the larger SRS’s must be separately crated with lots of padding around the speakers.

If you are within a reasonable (one day’s journey round trip) driving distance from the speakers you are interested in purchasing, by all means go and pick them up. I purchased my SDA SRS 1.2TLs from a seller who lived 7 hours from me. I rented a Ford AeroStar minivan and removed the two rear bench seats. The resulting space was just large enough for both of the 1.2TLs to lie side by side on their backs.

4.5 SDA Reviews

SDA technology was largely dismissed as a “gimmick” by the so-called “high end” audio publications. I have been able to only find ten reviews of SDA loudspeakers. There were probably others.

SDA 1, Stereo Review, December 1982
SDA CRS, Stereo Review, November 1984

SDA 2.3, Stereo Review, November 1988
SDA Technical Paper, Audio, June 1984

SDA SRS, Stereo Review, November 1985
SDA 2A, Stereo Review, December 1986
SDA 1C, Stereo Review, November 1987

SDA 1, High Fidelity, January 1983
SDA 2, High Fidelity, June 1984
SDA SRS 2, High Fidelity, November 1986.

The interested reader can find these reviews on microfilm/microfiche at most larger libraries. Review articles may also be ordered online from Roger Russel Audio Reviews at www.roger-russel.com/magrev.htm (**I have no affiliation with this website or its owner**).

The Audioreview.com website also has consumer reviews of many SDA models. Be sure to click on the “older models” link or the SDA’s will not appear in search results.

4.6 Room Placement

It is important to THOROUGHLY READ the owner’s manual prior to setup. Take care to follow the setup procedures outlined in the manual. If the pair you are considering for purchase does not come with a manual, one can be obtained free of charge from Polk Audio. Note that SDA’s require at least 3 feet of distance from the side walls and 6 to 8 feet of spacing between them for optimum performance. This means that the speakers must be placed along a wall at least 15 to 18 feet in length, depending on the speaker size. Reflections from nearby walls can negatively affect imaging. The listening position must be equal to or greater than the distance between the speakers.

There is a reason why it is not recommended to “toe in” SDA’s. SDA speakers use a phase compensation system wherein the bass/midrange (stereo) drivers are recessed relative to the tweeters. Recessing the stereo drivers results in a tilting of the effective axis of acoustic radiation by an angle of 20 degrees towards the listener. **Therefore, toe-in is already built into SDA speakers.**

I have read reports where toeing in SDA's subjectively improved the sound. However, these were situations where the recommended placement from side walls was impractical and toeing in the speakers served to reduce side wall reflections.

4.7 Amplification

SDA loudspeakers require clean, high current amplification for optimum performance. A minimum of 200 watts per channel is recommended. Inadequate amplification (and improper setup and room placement) can cause “muddy” bass and midrange reproduction. Additionally, the amplifier must be a common ground (both left and right channels share a common ground plane) design. Use of a non-common ground amplifier may result in a short circuit condition and may cause damage to your speakers and/or amplifier.

Some SDA's may be used with non-common ground amplifiers by using the Polk AI-1 Non-Common Ground Amplifier Interface. For some non-common ground amplifiers or mono block amplifiers, simply connecting the negative terminals of the two channels will work, although the user should check with the amplifier manufacturer to make sure that connecting the channel grounds in this fashion will do no harm. Very high powered amplifiers (above 300 watts per channel) are usually bridged designs and thus are usually not common ground amplifiers. The "negative" speaker terminals of such amplifiers, rather than being at ground potential, are live and are at an inverted potential of the positive terminal. Some examples of such amplifiers are the Bryston 14B SST stereo amplifier and the Pass Labs X600 mono block amplifiers.

Table 4.1. AI-1 Amplifier Interface Compatibility Chart

INSTRUCTIONS FOR USING THE SDA AI-1 AMPLIFIER INTERFACE	
The Polk Audio SDA Non-Common Ground Amplifier Interface permits the use of floating ground or separate monaural amplifiers to be used with SDA series loudspeakers. The interface is installed in place of the interconnect cable, connecting to the interconnect receptacle on the rear of each speaker cabinet.	
IMPORTANT!!	
The non-common ground amplifier interface can be used only with speakers with serial numbers greater than those listed in the following table. Attempts to use the amplifier interface with earlier units risk damage to the speakers, the amplifier, and the interface. If you have any doubt whether your speakers can be used with the interface, please contact Polk Audio.	
MODEL	SERIAL NUMBERS OF COMPATIBLE UNITS
SDA-1C	Left Channel #5975 or greater, Right Channel #6001 or greater
SDA-2B	Left Channel #14115 or greater, Right Channel #14124 or greater
SDA-CRS+	Both Channels #9371 or greater
SDA-SRS	Both Channels #5001 or greater
SDA-SRS 2	Both Channels #1945 or greater
NOTE: Some early units of SDA-1C and all units of SDA-2B require plug adapters and some internal modifications to the crossover to be used with the Non-Common Ground Amplifier Interface. The affected SDA-1C units can be identified by serial number as follows:	
Right Channel	#6001 through 6310 and #6501 through 6678
Left Channel	#5975 through 6370 and #6532 through 6656
If the serial numbers of your speakers fall within these limits, please contact Polk Audio for modification details.	

4.8 Used Market Prices For SDA's

Prices for SDA's on the used market vary wildly from month to month and from year to year. The prices for the largest (and rarest) SRS models in good condition are typically in the range of 60% to 75% of their new list price. Expect to pay (or receive) more for rare, one owner models in excellent to mint condition with original boxes, manual, and sales receipts.

Bluebook prices (Audiogon Bluebook, Orion Bluebook, etc.) are not realistic guides of what SDA's sell for, because, as with any "cult" item, there are often those willing to bid prices well above bluebook values. Be that as it may, sometimes the dreaded WAF and lack of space will combine to produce an awesome deal for the buyer. I have been the recipient of a couple of fortuitous deals under those circumstances.

Bear in mind that the market value of an item equates to only what someone is willing to pay for it. Also be mindful of the fact that these are large, imposing speakers. If you are looking to sell a pair, remember that you are selling a "niche" item. Most people (i.e. most wives) do not want large monolithic speakers in "their" living room or even in "their" house.

A good idea of current market prices can be gained from searching Audiogon, eBay and the Polk Audio Internet forum.

4.9 Quick Tests to Determine Proper Functioning of SDA Loudspeakers

Assumptions

1. The speakers are connected to a common-ground amplifier, in correct absolute phase (i.e., "+" amplifier terminal to "+" speaker terminal).
2. The speakers are correctly positioned. The front faces of the two units must lie in the same plane; the speakers must not be "toed-in" if they are to work properly. The left-channel speaker **MUST** be in the left position, and the right-channel speaker **MUST** be in the right position, viewed from the listening position.

Procedures

1. With a monaural broadband signal such as interstation noise on an FM tuner, set the balance control in the center position. The sound image should now be positioned directly in the center, between the two speakers. The "dimensional" tweeter(s) (if any) and driver(s) on each speaker (see manual) should now be inactive. Note that, because SDA's use sealed (airtight) cabinets, the dimensional driver may vibrate in sympathy with the sound being produced by the "stereo" drivers, but is not itself actively producing sound. Now, rotate the balance control to the left, the image should now shift decidedly to the left, appearing to the left of the left-channel speaker. All the drivers and tweeters on the left-channel speaker should now be producing sound; on the right-channel unit, however, only the "dimensional" driver and tweeter should be operating.

Similarly, when the balance control is rotated to the right, the situation is reversed, with all right-channel drivers and tweeters active and only the dimensional driver and tweeter active in the left-channel unit.

If the dimensional drivers and tweeter fail to produce sound when the balance control is rotated to the right, then it is likely that the right-channel unit has been connected to the amplifier in reverse phase. If the fault occurs when the balance is rotated left, then check the left-channel connections. Check the phase of both channels if the dimensional drivers fail to work at all.

With some amplifiers, the common inter-channel connection is made through the positive terminals, rather than the negative terminals. In this case, the speakers behave as though both units were connected in reverse phase, and the dimensional drivers will not work; this can be corrected by wiring BOTH units in reverse phase.

2. Disconnect the speaker cable from the black terminals on both the left- and right-channel units. Using the same monaural broadband signal as in (1), rotate the balance control to the left. Only the dimensional speaker of both left- and right-channel units should now be active. The sound should have an odd, “spacey” quality to it, and from the listening position should sound as if it is coming from nowhere in

particular. It should also be lacking in bass content. As the balance control is rotated from the left position, the amplitude of the sound should diminish, almost completely disappearing at the center balance position, then reappear and return to its original level at the rightmost balance position. It should still have the same odd sonic qualities.

The test signal to which you have just been listening represents the “difference” between the left- and right-channel signals. For best operation of the SDA speakers, the balance control should now be set to that this difference test signal is minimized.

If, when the balance control is rotated to either extreme, the sound source appears to be located firmly in the center between the two speaker systems, this is an indication that one of the sets of dimensional speakers is wired out-of-phase. In this case, the ground wires should be reconnected to both the left- and right-channel systems, and test #1 (above) should be performed. This time, during test #1, the balance control will be rotated, and each speaker system will be evaluated for bass output. If one unit produces a markedly lower output in the bass region, it is likely that this is the unit with the out-of-phase dimensional driver and/or tweeter. A driver or tweeter is correctly wired when the BLACK lead is connected to the terminal marked with a dot or red paint (driver) or a red washer under the terminal (tweeter).

3. Several checks can be performed with a Volt/Ohm meter (VOM) to verify that certain internal connections are in order. These involve measurements of resistance between pins of the interconnect cable socket and the red (+) and black (-) binding posts, all on the backs of the speakers. For blade-blade sockets, pin #1 is the larger of the two. For pin-blade sockets, Pin #1 corresponds to the blade socket. The following measurements are for a RIGHT-CHANNEL speaker; for a left-channel unit, simply exchange the pin numbers for the interconnect socket:

Note: Measurements taken with all cables disconnected from the speakers.

Table 4.2. Proper Resistance Values.

Measure Between	SDA 2	SDA 1A	SDA CRS
I.C. pins 1 & 2	10.5 +/- 10%	10.5 +/- 10%	7 +/- 10%
I.C. pins 1 & (+)	0 (< .3)	0 (< .3)	0 (< .3)
I.C. pins 2 & (+)	10.5 +/- 10%	10.5 +/- 10%	7 +/- 10%
I.C. pins 1 & (-)	4.6 +/- 20%	3.4 +/- 20%	7 +/- 20%
I.C. pins 2 & (-)	15.3 +/- 20%	13.5 +/- 20%	13.5 +/- 20%
(+) & (-)	4.8 +/- 20%	3.4 +/- 20%	7 +/- 20%

Table 4.3. SDA Wiring Checkpoints.

Test Data Variable	DC Resistance (DCR) Checkpoints.	Right Channel	Left Channel
SDA 1 (ORIGINAL)			
		Ohms	Ohms
R1	IC PIN #2 TO BLACK TERMINAL	INF	5.50
R2	IC PIN #1 TO BLACK TERMINAL	5.50	INF
R3	IC PIN #1 IC PIN #2	INF	INF
R4	IC PIN #2 TO RED TERMINAL	INF	0.10
R5	RED TERMINAL TO BLACK TERMINAL	5.50	5.50
R6	IC PIN #1 TO RED TERMINAL	0.10	INF
SDA 1A			
R1	IC PIN #2 TO BLACK TERMINAL	13.50	3.30
R2	IC PIN #1 TO BLACK TERMINAL	3.30	13.5
R3	IC PIN #1 IC PIN #2	10.00	10.0
R4	IC PIN #2 TO RED TERMINAL	10.00	0.00
R5	RED TERMINAL TO BLACK TERMINAL	3.30	3.30
R6	IC PIN #1 TO RED TERMINAL	0.00	10.0
SDA 2			
R1	IC PIN #2 TO BLACK TERMINAL	15.50	4.80
R2	IC PIN #1 TO BLACK TERMINAL	4.80	15.50
R3	IC PIN #1 IC PIN #2	10.50	10.50
R4	IC PIN #2 TO RED TERMINAL	10.50	0.00
R5	RED TERMINAL TO BLACK TERMINAL	4.80	4.80
R6	IC PIN #1 TO RED TERMINAL	0.00	10.50
SDA CRS			
R1	IC PIN #2 TO BLACK TERMINAL	13.50	6.80
R2	IC PIN #1 TO BLACK TERMINAL	6.80	13.50
R3	IC PIN #1 IC PIN #2	7.00	7.00
R4	IC PIN #2 TO RED TERMINAL	7.00	0.00
R5	RED TERMINAL TO BLACK TERMINAL	6.80	6.80
R6	IC PIN #1 TO RED TERMINAL	0.00	7.00
NOTE: IC PIN #1 IS LARGE BLADE, IC PIN #2 IS SMALL BLADE ON INTERCONNECT.			

Table 4.4. SDA Wiring Checkpoints.

Test Data Variable	DC Resistance (DCR) Checkpoints.	Right Channel	Left Channel
SDA SRS 1.2 / SRS 1.2TL			
		Ohms	Ohms
R1	IC PIN #2 TO BLACK TERMINAL	2.20	2.20
R2	IC PIN #1 TO BLACK TERMINAL	0.00	0.00
R3	IC PIN #1 IC PIN #2	2.20	2.20
R4	IC PIN #2 TO RED TERMINAL	3.00	3.00
R5	RED TERMINAL TO BLACK TERMINAL	3.60	3.60
R6	IC PIN #1 TO RED TERMINAL	3.60	3.60
SDA SRS 2.3			
R1	IC PIN #2 TO BLACK TERMINAL	3.10	3.10
R2	IC PIN #1 TO BLACK TERMINAL	0.00	0.00
R3	IC PIN #1 IC PIN #2	3.10	3.10
R4	IC PIN #2 TO RED TERMINAL	3.10	3.10
R5	RED TERMINAL TO BLACK TERMINAL	4.00	4.00
R6	IC PIN #1 TO RED TERMINAL	4.10	4.10
SDA SRS 2 (New Connector)			
R1	IC PIN #2 TO BLACK TERMINAL	1.80	1.8 0
R2	IC PIN #1 TO BLACK TERMINAL	0.00	0.00
R3	IC PIN #1 IC PIN #2	1.80	1.80
R4	IC PIN #2 TO RED TERMINAL	3.00	3.00
R5	RED TERMINAL TO BLACK TERMINAL	3.70	3.70
R6	IC PIN #1 TO RED TERMINAL	3.70	3.70
SDA CRS+ (New Connector)			
R1	IC PIN #2 TO BLACK TERMINAL	2.2 0	2.20
R2	IC PIN #1 TO BLACK TERMINAL	0.00	0.00
R3	IC PIN #1 IC PIN #2	2.20	2.20
R4	IC PIN #2 TO RED TERMINAL	3.00	3.00
R5	RED TERMINAL TO BLACK TERMINAL	3.70	3.70
R6	IC PIN #1 TO RED TERMINAL	3.70	3.70
NOTE: ALL CROSSOVERS WITH A PIN AND BLADE INTERCONNECT (New Connector) WILL HAVE THE BLADE = PIN #1 AND THE PIN = PIN #2.			

Table 4. 5. SDA WIRING CHECK POINTS

Test Data Variable	DC Resistance (DCR) Checkpoints	Right Channel	Left Channel
SRS			
		Ohms	Ohms
R1	IC PIN #2 TO BLACK TERMINAL	INF (843)	4.30
R2	IC PIN #1 TO BLACK TERMINAL	4.30	INF (843)
R3	IC PIN #1 IC PIN #2	INF (843)	INF (843)
R4	IC PIN #2 TO RED TERMINAL	INF (843)	0.00
R5	RED TERMINAL TO BLACK TERMINAL	4.30	4.30
R6	IC PIN #1 TO RED TERMINAL	0.00	INF (843)
SDA 2 / SDA 1B			
R1	IC PIN #2 TO BLACK TERMINAL	INF (843)	4.30
R2	IC PIN #1 TO BLACK TERMINAL	4.30	INF (843)
R3	IC PIN #1 IC PIN #2	INF (843)	INF (843)
R4	IC PIN #2 TO RED TERMINAL	INF (843)	0.00
R5	RED TERMINAL TO BLACK TERMINAL	4.30	4.30
R6	IC PIN #1 TO RED TERMINAL	0.00	INF (843)
SDA-2A / SDA CRS+			
R1	IC PIN #2 TO BLACK TERMINAL	INF (843)	4.00
R2	IC PIN #1 TO BLACK TERMINAL	4.00	INF (843)
R3	IC PIN #1 IC PIN #2	INF (843)	INF (843)
R4	IC PIN #2 TO RED TERMINAL	INF (843)	0.00
R5	RED TERMINAL TO BLACK TERMINAL	4.00	4.00
R6	IC PIN #1 TO RED TERMINAL	0.00	INF (843)
NOTE: IC PIN #1 IS LARGE BLADE, IC PIN #2 IS SMALL BLADE ON INTERCONNECT			

SDA DC Resistance (DCR) Checkpoint Worksheet

MODEL_____

SERIAL #._____

DCR CHECKPOINTS

RIGHT CHANNEL

LEFT CHANNEL

- IC PIN #2 TO BLACK TERMINAL
- IC PIN #1 TO BLACK TERMINAL
- IC PIN #1 TO IC PIN #2
- IC PIN #2 TO RED TERMINAL
- RED TERMINAL TO BLACK TERMINAL
- IC PIN #1 TO RED TERMINAL

REF.	MEAS.	REF.	MEAS.

NOTE:

OLD CONNECTOR - IC PIN #1 = LARGE BLADE; IC PIN #2 = SMALL BLADE

NEW CONNECTOR - IC PIN #1 = BLADE; IC PIN #2 = PIN

COLOR CODE:

OLD CONNECTOR - RIGHT CHANNNEL: PIN #1 = BLUE; PIN #2 = WHITE; LEFT CHANNNEL: PIN #1 = WHITE; PIN #2 = BLACK

NEW CONNECTOR - RIGHT & LEFT ARE THE SAME; PIN #1 = WHITE; PIN #2 = BLUE

SKETCHES:

Chapter 5

New SDA Tweeters!

There are not many manufacturers who are willing to support a product line that was discontinued twenty years ago. Polk Audio provided improved versions of the SL2000 and SL3000 tweeters in 2003. The SL2000 and SL1000 were replaced by the RD0194-1 and the SL3000 was replaced by the RD0198-1. The SL2000 earned some critics due to a +5 dB resonance peak at 13,000 Hz. There were others who liked the added “detail” and brightness of the SL2000. The SL3000 was a huge improvement in high frequency accuracy over the SL2000, but was only available in the top-of-the-line SRS series. Furthermore, some listeners thought that the SL3000 added a bit of “graininess” to some recordings. The RD0194-1 is a drop-in replacement for the SL2000. For an SL1000 replacement, the mounting hole will have to be routed out a little to accommodate the larger size of the RD0194-1. Some purchasers of the RD0194-1 have reported that it is a closer sonic match to the SL2000 than the SL1000. Whether you are using the RD0194-1 to replace an SL1000 or an SL2000, you will have to replace all of the SL1000’s/SL2000’s in a pair of SDA’s to achieve coherent sound. The sound of the RD0194-1 is different enough from both the SL1000 and the SL2000 to prevent it from “blending in” with either. On the other hand, the RD0198-1, does not “stand out” as objectionably from a group of SL3000 tweeters. On instrumental material, I could not hear a difference between the SL3000 and the RD0198-1. I heard a difference, and a definite improvement, with the RD0198-1 on vocal material.

According to Matthew Polk, the firing order of the four-tweeter SRS’s from highest to lowest was “...2, 3, 4, 1 with 1 being the tweeter closest to the floor. The crossover points are not standard slopes. The idea was to arrange the high end roll-off of each tweeter to achieve constant vertical directivity vs. frequency. Vertical directivity is determined by the ratio of the wavelength to the length of the line source. The four tweeters create a line source which, if they all covered the same frequency range, would become more directive at higher frequencies (shorter wavelengths). By progressively rolling off tweeters, the line source becomes effectively shorter at higher frequencies. By carefully choosing the roll-off characteristics of each tweeter, the output of all the tweeters adds up to flat response and pretty much constant vertical dispersion across the range covered by the tweeter array.”

The only visual difference between the RD0194-1 and the RD0198-1 is that the RD0194-1 has two narrow connection tabs of the same size on the rear whereas the RD0198-1 has a wide and a narrow connection tab on the rear. The positive terminals of both tweeters are marked with red paint. The SL2000 and SL3000 had a “+” sign engraved into the plastic near the positive terminal. Additionally, the SL3000, like the RD0198-1, had connection tabs which were different sizes, making it impossible to make a wrong connection. The DC resistance of the RD0194-1 and the SL2000 is 7.5 ohms. The DC resistance of the RD0198-1 and the RD0198-1 is 5.6 ohms.

If you call Polk customer service, there is the very real possibility that you might get a service representative who is not knowledgeable about parts for 20 year old SDA’s . The customer service representative may not know what an “SL2000” or an “SL3000” is. Do not ask for the “SL2000 replacement” or “SL3000 replacement”. Ask for the respective

replacement tweeter by its part number: RD0194-1 or RD0198-1. Following are photographs of the SL2000, SL3000, RD0194-1, and RD-0198-1 tweeters



Figure 5.1. Front of the RD0194-1 tweeter.

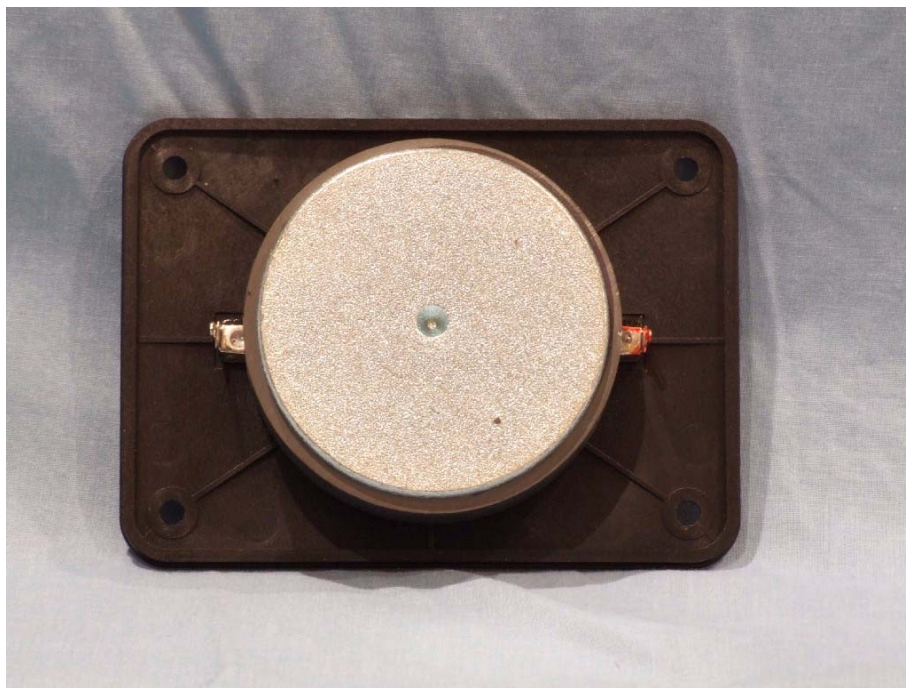

Figure 5.2. Rear of the RD0194-1 tweeter.



Figure 5.3. Front of the RD0198-1 tweeter.



Figure 5.4. Rear of the RD0198-1 tweeter.



Figure 5.5. Front of the SL2000 tweeter.



Figure 5.6. Rear of the SL2000 tweeter.



Figure 5.7. Front of the SL3000 tweeter.



Figure 5.8. Rear of the SL3000 tweeter.

Chapter 6

SDA Modifications

6.1 Introduction

With any audio electronics, it is always best to consult the manufacturer prior to doing any modifications. They often can provide valuable insight regarding what to do and advisement regarding what not to do.

The Polk Audio Internet forum is an extensive resource of detailed, and often step-by-step, SDA modification information. Some of the older information may be difficult to find using the forum search feature. Fortunately, Internet search engines, such as Google, offer excellent search functionality of the forum's information. For example, searching on the terms "SDA rings", "SDA inductor", "SDA PCB", and "SDA modification" in Google brings up several relevant Polk forum threads for each topic.

6.2 Recommended Modifications

Consumer electronics equipment is made to be offered at specific price points. This requires certain cost-cutting measures (e.g. construction techniques and parts quality) which diminish performance. In some cases, a manufacturer may desire to use better or premium quality parts, but such parts may not be available in sufficient quantities. Premium crossover parts (resistors, film capacitors) were not available in sufficient quantities when the SDA series was in production. Polk's engineering department was very forthcoming with information regarding where corners were cut and what improvements could be made to improve sonic performance. The following modifications are recommended by Polk Audio's engineering department:

1. Apply damping material (foam tape or Dynamat Xtreme) to the metal driver baskets to reduce ringing.
2. Replace the stock grille cloth with a lighter, more sonically transparent fabric.
3. Remove (or short) the semiconductor tweeter protection device (polyswitch). The polyswitch does veil the sound. **Careful!!** This is not recommended if you are using a low power amplifier and listen at high sound levels. Clipping distortion could destroy the tweeters.
4. Replace the stock SL1000, SL2000 and SL3000 tweeters with the silk dome upgrades RD0194-1 and RD0198-1.
5. Replace the large SDA circuit inductor with a lower DCR inductor of equivalent inductance.
6. Replace the electrolytic and mylar film capacitors with high quality polypropylene film capacitors (eg. Sonicap).
7. Replace the ceramic metallic resistors with lower noise, lower inductance resistors (eg. Mills MRA-12).

8. Replace the standard AI-1 Non Common Ground Interface with a high current toroidal isolation transformer.
9. Replace the foam tweeter, driver and passive radiator seals with Mortite caulking cord.
10. "TL" modification for 1989 version SDA CRS+ and SDA 2B to allow use of Either SL3000 or RD0198-1 tweeters.

The following modifications have been tested and proven by experienced SDA modifiers and are highly recommended:

1. Replace the stock binding posts with higher quality posts for better mechanical connection (eg. Vampire or Cardas).
2. Replace the stock binding post straps (on bi-wireable/bi-ampable SDA's) with high quality heavy gauge (12 gauge or larger) speaker wire.
3. Replace the interconnect cable with heavier gauge wire.
4. Replace the stock crossover printed circuit board with a custom printed circuit board or use point-to-point wiring on a wooden board. Premium crossover components are much larger than the stock components. These larger parts present placement challenges on the small SDA crossover circuit boards.
5. Replace the tweeter, driver and passive radiator retaining screws with steel brackets and steel rings for better coupling to the cabinet and improved bass response and overall clarity.
6. Completely wrap the standard AI-1 Non-Common Ground Interface in five or more sheets of aluminum foil to shield against environmental noise.

The use of Mortite caulking cord was recommended as a higher performance alternative to foam tape seals by Matthew Polk:

"Any of the foam tapes sold for weather stripping will work as well as the original. Use the light weight foam and the thinnest you can find. Do not use the heavier and usually thicker black foam rubber. For a better appearance, a little searching can probably turn up a dark colored tape that will match the baffle and basket color better than the standard grayish tape found in most hardware stores.

The idea here is to provide the best possible connection between the drivers, tweeters and PR's and the baffle. That means using the thinnest gasket that will actually provide a seal. However, there is a higher performance alternative. In the early days before we could afford to tool gaskets we used a product called Mortite which was a gray flexible clay-like material sold as weather stripping and for sealing up leaky windows in winter. We would roll it out, by hand, into round wire-like cords and apply to the driver baskets before bolting in place. I always felt that it did a better job of connecting the drivers to the baffle.

Caution; if you decide to try this it is much easier to strip out the screws for the drivers, tweeters, etc. Use as little material as needed to make a seal, apply evenly and carefully tighten the screws a little at a time going around the basket so that the load is always evenly distributed over all the screws."

6.2.1 SDA Crossover Inductor Replacement

With the exception of the large SDA inductor, Polk Audio does not recommend changing the other crossover circuit inductors in SDA's. Polk's Engineering Vice President, Stu Lumsden, explained why:

"The DCR of our inductors is accounted for in the crossover design. Changing it / lowering it will affect a different balance than the design intent. We typically use large enough wire that the DCR of the woofer inductors is in tenths of an ohm range. As to switching inductor for reasons of other qualities, there can be benefits if the designer has not done his homework. We've used air-core inductors for many designs and steel or iron cores for others. We base our decisions on the perceived use of the product, cost and size. Iron or steel cores increase the value of a given inductor by focusing the magnetic field created by the windings. This has the advantage of reducing the size and number of winds needed to achieve an inductance value. This also means that larger wire or fewer turns can be used to achieve a lower DCR. The concern is that the core (iron, steel laminate, ferrite) will saturate a some maximum field intensity and pushing current above that level into the inductor will make it become non-linear. The inductor is actually reverting to acting like an air-core as it is over-driven – but only for the overdriven portion of the signal. So the signal becomes distorted, bad noises, scratchy, etc. We have to choose the wire gauge and core material so as to provide head-room for the largest signals (including transients) that we expect the speaker to reproduce linearly. Air-core inductors do not saturate as more current is passed through them unless the current is so great that the wire begins to heat. It is not necessary, however, for the inductors to have such high limits because there are plenty of other practical limitations on loudspeaker output. Many of these are simply physical, like the maximum possible cone excursion of the drive units. Go beyond this and once again – distortion. Typically we can design our speakers with steel-laminate inductors and easily reach undistorted levels well in excess of 100 dB in the case of appropriately sized units. The down side of air-core inductors is as mentioned earlier that they will require more wire and hence have higher DCR. So more power from the amp will go into heating up this inductor and less into making sound. In this case, resistance is indeed futile."

Matthew Polk discusses replacement of the large SDA circuit inductor:

"Usually, in a typical low pass crossover, one would not want to swap out an inductor for another one with much different characteristics because it would alter the voicing of the speaker. However, in this case there could be a performance benefit if the amp being used doesn't mind seeing a lower impedance. The inductor I believe they are talking about is part of the "Full Complement Sub-Bass Drive"

circuit. That's a term that Sandy coined to describe the system we used to allow the SDA drivers to work in parallel with the stereo drivers in the bass while producing the SDA signal at higher frequencies.

In this generation of the SDA's the stereo drivers were nominally 6.5 ohms and the SDA drivers were nominally 3.5 ohms. The plus terminals of the SDA drivers on each side were connected to the plus amp terminal on that side via their cross-over network. Then, the negative terminals of the SDA drivers on one side were connected to the negative terminals of the SDA drivers on the other side via the interconnect cable. This causes the SDA drivers on the right to produce an R-L signal and the ones on the left to produce L-R. Since bass is pretty much mono in most recordings, if the SDA drivers both get full-range R and L signals they would cancel at low frequencies and the SDA drivers would just sit there acting like badly tuned passive radiators. So, we added an inductor in each speaker between the SDA driver negative terminal and the amp negative terminal on that side. At low frequencies that diverts the signal back to ground instead of through the interconnect to the SDA drivers in the other speaker. As a result, at very low frequencies the Right SDA drivers produce only right channel bass and vice versa, while still producing the R-L and L-R signals at higher frequencies. The transition occurs between about 50Hz and 150Hz.

However, because of the DC resistance of the inductor, the system isn't perfect. I don't recall the DC resistance of these coils but it was high, at least several ohms depending on the model. This means that the SDA drivers will continue to produce some SDA signal even at very low frequencies. Decreasing the DC resistance will definitely improve the bass response of the system both qualitatively and quantitatively. However, before you rush out to buy those Hi-Q replacement inductors be aware of some concerns.

We chose the higher DC air core coils for a couple of good reasons. First, we were always on the edge of acceptability with the impedance of the SDA's. The DCR of these coils kept the minimum impedance high enough for the amps available in those days. Depending on the model, reducing the DC resistance of these coils may take the minimum impedance down to around 2 ohms. If your amp doesn't mind, you shouldn't either. The other concern is saturation of the inductor core. Air core inductors don't saturate. Given the cost of adequate ferrite or laminated core inductors at the time, plus the need for a higher DCR, the air core choice was obvious. So, when switching to a ferrite or laminated core inductor make sure it will handle at least 5 amps without saturation. That's equivalent to 100 watts of low frequency power through the SDA driver.

As an addition to the thoughts I gave earlier on inductor quality you should advise that only laminated steel is acceptable for most any high quality system. Ferrite saturates at current levels much too low. It's high permeability allows one to make very high inductance values with less wire (so lower DCR) but the current range is poor at best. For all I know this may be the reason that all quality / high current transformers use laminated steel."

6.3 Modification Benefits

People will read about the spectacular results that someone achieved with an SDA modification and want to rush out and do the same thing and get the same results. Some people buy a new pair of SDA's and begin modification without spending significant time listening to the stock, unmodified speakers in order to establish a performance baseline.

Table 6.1 Specific SDA Modification Benefits

Modification	Benefit
Damping material on driver baskets to reduce ringing.	Improved clarity and detail.
Lighter, thinner grille cloth.	Improved clarity and detail.
Polyswitch removal.	Improved clarity and detail.
RD0194-1 and RD0198-1 tweeters.	Improved high frequency clarity, detail and smoothness.
Lower DCR SDA inductor.	Improved bass detail and impact.
High grade capacitors and resistors.	Improved imaging, sound staging, clarity and detail.
Replace the standard AI-1 Interface with toroidal isolation transformer.	Improved imaging, sound staging, clarity and detail.
Mortite speaker seals.	Improved bass detail, impact and articulation.
“TL” crossover modification.	Improved high frequency clarity, detail and smoothness. Improved upper bass detail.
Replace binding posts.	Better mechanical connection, especially for heavy speaker cables.
Replace binding post straps.	Improved overall high frequency detail and clarity.
Heavier gauge SDA interconnect cable.	Improved overall clarity and detail.
Custom circuit board or point-to-point wiring.	More space for larger components. Improved clarity due to lower noise interference from adjacent components.
Steel tweeter brackets and driver and passive radiator rings.	Improved cabinet coupling resulting in better bass detail, articulation and clarity. Improved overall clarity and detail.
Wrap the standard AI-1 Interface with 5 or more sheets of aluminum foil.	Improved imaging, sound staging, clarity and detail due to improved shielding against environmental noise.

The fact is, unless you have the same speakers, listening room, electronics and **EARS** as someone else, you probably won't achieve the same results as someone else. Another important fact is that most experienced SDA modifiers (hotrodders) perform modifications in stages. Weeks, months, even years may elapse between modifications. This allows sufficient time to gauge performance improvement before moving to the next stage of modification. Be patient. Take the time to become familiar with the sound of your SDA's...then start tweaking. Table 6.1 summarizes the general sonic benefits that can be achieved with specific modifications.

6.4 Modification Costs

How much money can you spend modifying a pair of SDA loudspeakers? Anywhere from a couple of hundred dollars for a simple tweeter upgrade to a couple of thousand dollars for a full upgrade of one of the large SRS SDA's. The Polk forum provides much detailed information on specific modification costs incurred by various members.

6.5 Custom AI-1 Non-Common Ground Amplifier Interface

SDA loudspeakers must be used with common ground amplifiers, i.e. amplifiers whose two channels are connected to the same ground point. Some non-common ground stereo amplifiers and some monoblock amplifier pairs can be configured as a common ground system by connecting (strapping) the negative binding posts of each channel together. This works, but it is not optimal since the amplifier channels were designed to be isolated from each other. Strapping a non-common ground stereo amplifier or a pair of mono amplifiers can result in diminished sound quality due to increased electrical noise. Such noise affects stereo imaging, sound staging clarity and detail. Even with amplifiers whose left and right ground channels can be tied together, a custom high current AI-1 is a higher performance alternative.

If you want to use a non-common ground (floating ground) amplifier or a pair of monaural amplifiers (whose ground channels cannot be strapped together) with your SDA's AND your SDA's are suitable for use with the AI-1 Non-Common Ground Amplifier Interface (see table 4.1, page 31), you will either have to find someone to make one for you or make it yourself. Polk Audio no longer sells the AI-1, although they infrequently show up on the used market. The AI-1 Interface is an isolation transformer that is connected to SDA speakers in place of the regular SDA interconnect cable. Please note that the AI-1 Interface can only be used with certain SDA's that use the pin/blade SDA interconnect.

There have been mixed results with the standard AI-1. Some people who have used one stated that the interface cable slightly diminished musical clarity and detail. Others have said they heard no difference with the AI-1 in place. As with most things in audio, your results will depend on your ears and equipment. If you are planning to use a higher powered non-common ground amplifier (above 300 watts per channel), you may want to consider building an AI-1 with a heavy duty toroidal transformer (described in section 6.7.3) in order to avoid saturation issues.

6.6 Standard AI-1 Non-Common Ground Amplifier Interface Fabrication

These instructions, which were provided by Ken Swauger of Polk Audio, are for someone who already has a pin-blade connecting cable and wants to convert it to a non-common ground version. Use a good quality speaker cable if you do not have or do not want to cut up your stock SDA interconnect. The following parts are required:

1). An isolation transformer such as:

SPC Technology 81N5406, \$15.99 or,
Stancor 01F043, \$20.04 or,
Magnetek Triad 03F1017, \$16.46.

Each of these transformers are small with approximate dimensions (WLH) of 2" x 3" x 2". These can be purchased from the Newark catalog parts company (www.newark.com), phone 1-800-463-9275.

2). A 20' length of good quality #16 or #14 gauge speaker wire.

3). A Volt/Ohm meter (VOM)

4). Two "clip leads" (a short length of connecting wire with an alligator at both ends).

First step: the isolation transformer should have four leads coming from it; two for the primary and two for the secondary sections of the transformer. It may look like this:

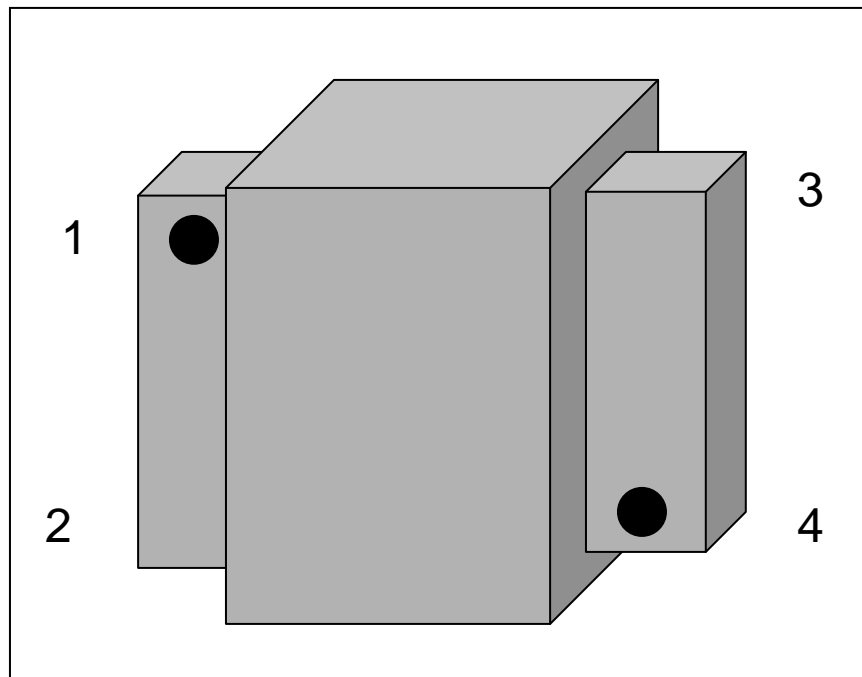

Figure 6.1. Transformer Orientation Diagram

Connections 1 and 2 would correspond to the primary and 3 and 4 would correspond to the secondary. In order to test this, you would set your VOM to the lowest resistance setting. The meter will have a positive test lead and a negative test lead. If you touch the two leads together you should see "0" ohms displayed on the meter. Now, using the meter's two leads, place them on connections 1 and 2 of the transformer. You should read a low result on the meter. The same test can be done to connections 3 and 4 and you should find the same low reading. However, placing your meter's test leads across connections 1 and 3 or 2 and 4 should show an "infinite" resistance corresponding to no connection at all.

The second step is to take your pin-blade SDA cable and cut it into two pieces. The cut should be made wherever you wish to have the isolation transformer inserted. Once this is done you should see the two wires inside the cable itself, one white and the other black. It is important to note that both of these wires are connected to the pin part of each pin-blade connector. Neither one of these two wires is connected to the blade; only the pin is conductive from one end of the cable to the other. However, for the operation of the isolation transformer we will have to use a separate piece of speaker wire to make this necessary connection.

Separate the two halves of the pin-blade cable into a "right" and "left" cable. Take the "left" half of the cable and remove enough of the outer insulation to expose the two wires. Cut off 1" or 2" of the black wire leaving the remaining white wire longer and remove 1" of the white insulation exposing the copper wire. This wire should be soldered to connection 1 of the isolation transformer. Take the #16 or #14 gauge speaker wire and cut it to the same lengths that the pin-blade cable was cut to. Take the section of the speaker wire that corresponds to the "left" piece of the pin-blade cable and remove 1" insulation from one end. This wire should be soldered to connection 2 of the isolation transformer. Now you have completed the left half of the AI-1 cable. The pin-blade connector would go into the left SDA speaker, the other end of the speaker wire would be connected to the negative terminal of the five way binding post of the left speaker.

Now construct the "right" half of the cable. Take the remaining length of the original SDA pin-blade cable and remove enough of the outer insulation material to expose the two wires inside. Cut off 1" or 2" of the black wire leaving the white wire longer. Remove 1" of insulation from the white wire, but don't connect it at this point. Take the remaining portion of the speaker wire and remove 1" of insulation from both ends. The next test is going to determine the proper polarity of the secondary of the isolation transformer. In order to do this you would connect your power amplifier or receiver to the left and right speaker (note: this doesn't have to be the non-common ground amplifier; any power source would be fine). The right positive and negative connections of the amplifier would go to the right speaker's positive and negative binding posts. The same with the left channel of the amplifier, it would be connected to the left speaker's positive and negative binding posts.

The left portion of the "under construction" AI-1 cable would be plugged into the pin-blade connection of the left speaker, the piece of speaker wire that is connected to terminal 2 of the isolation transformer would be connected to the negative five way binding post of the left speaker along with the negative wire of the speaker cable coming from the amplifier.

The same would be done to the right pin-blade connector, it would be plugged into the right speaker's pin-blade connector and the remaining section of speaker wire would be connected to the right speaker's negative binding post. However, the other ends of these wires are not yet connected to either terminal 3 or 4. The "clip leads" will be used to determine which wire should be connected to terminals 3 and 4. As an initial test, use one of the clip leads and connect it to the white wire of the original SDA cable and connect it to terminal 4. Then take the remaining clip lead and connect the piece of speaker wire to terminal 3.

Now turn your audio system on and begin playing a musical selection that is known to be a stereo signal. Make sure that there are sounds coming from all of the tweeters and drivers that make up your SDA speaker. Once this has been determined remove the negative speaker wire connections from the amplifier. Now the "stereo" portions of both the left and right speaker should not have any sound being played. However there should be sound coming from the "SDA" portions of both speakers. Note the relative strength of this sound and without touching the volume control reverse the clip leads connected to the two terminals. Note if the signal is now stronger or weaker than the previous connection.

You should also listen for the "diffuseness" of the sound, one of the two connection arrangements should seem more diffuse or "spacey". Note the connection arrangement that produces the stronger SDA signal.

Now, that the correct polarity has been determined, the final connections can be made to the secondary section of the isolation transformer. It is important to make sure that the transformer is placed into some kind of enclosure or housing to prevent anything from shorting out the connections. The Newark Company or a local electronics parts supply store such as Radio Shack can supply metal enclosures. All connections to the speakers and the amplifier should be neatly made with no stray wires.

6.7 High Current Custom AI-1 Non-Common Ground Amplifier Interface

According to Matthew Polk, for a high current AI-1 application, a 1:1 toroidal transformer will work very well. The key specifications are:

- “1. The DC Resistance of the primary and secondary should be less than .8 ohms and preferably less than .5 ohms. The lower the better.***
- 2. Inductance of both primary and secondary should be at least 10 mH. Ideal is around 14 mH.***
- 3. Current capacity to saturation should be 5 Amps minimum.***
- 4. Of course, the turns ratio is 1:1.***

Multiple transformers can be used in parallel to lower the DC resistance and increase the current capacity. Just remember that the inductance is half for two transformers in parallel and one-fourth for 4 transformers in parallel.”

The following Avel-Lindberg transformer meets the basic specifications provided by Matthew Polk:

Avel Part No. Y236906, 6.3" diameter, 2.2" high, weight: 13.2 pounds.

The approximate 2011 cost with shipping is in the range of \$120. Avel-Lindberg can also custom manufacture a toroidal transformer that is an exact match for the specifications given above, but this would be 2x to 2.5x the cost of an off-the-shelf transformer. Of course, there are other options from other transformer manufacturers.

References

1. 1983 Polk Audio Product Line Brochure, Polk Audio, Inc.
2. Audio Magazine, October 1985 Polk Audio Advertisement Spread
3. 1986 Polk Audio Product Line Brochure, Polk Audio, Inc.
4. 1987 Polk Audio Product Line Brochure, Polk Audio, Inc.
5. 1989 Polk Audio SDA TL Series Brochure, Polk Audio, Inc.
6. SDA SRS 1.2TL, 2.3TL, 3.1TL Owner's Manual, Polk Audio, Inc.
7. SDA SRS 1.2, 2.3 Owner's Manual, Polk Audio, Inc.
8. SDA SRS Owner's Manual, Polk Audio, Inc.
9. SDA 1C, 2B, CRS+ Owner's Manual, Polk Audio, Inc.
10. SDA 1B Owner's Manual, Polk Audio, Inc.
11. Stereo Review, November 1985, SDA SRS Review
12. Polk Audio website, www.polkaudio.com, Polk Audio, Inc.
13. 1990 Polk Audio RTA Series Brochure, Polk Audio, Inc.
14. A I-1 Non-Common Ground Amplifier Interface Plans, Ken Swauger, Polk Audio Customer Service Department. Polk Audio, Inc.

Appendix 1

SDA Technology Technical Paper

This paper was originally published in the June 1984 issue of Audio magazine. It provides a thorough technical discussion of Stereo Dimensional Array (SDA) technology.

S POLK'S S SDA SPEAKERS

Designed-In Stereo

MATTHEW POLK

When made commonly available in the 1950s, stereo revolutionized the quality of reproduced sound. Originally conceived before the turn of the century, stereo reproduction was not made practical until the invention of a stereo disc recording and playback system at Bell Labs during the early 1930s. Due to the economic effects of the Depression and the turmoil of World War II, stereo was not introduced to the general public until the 1950s. In the interim, many fundamental works on acoustics and sound reproduction were written, but from a strictly monaural point of view. A framework of monaural theory was created, within which sound-reproducing equipment, mainly transducers, was designed and its performance judged. Stereo, in no small measure, owed its success to its superficial compatibility with existing monaural equipment and the fact that engineers could apply familiar monaural concepts to the design of equipment for stereo. The first stereo systems offered were, in fact, two separate and complete mono systems linked by a common volume control and fed by a "new" stereo disc player. The concept of stereo as "dual mono" reproduction continues to this day, especially as regards the design of loudspeakers. In addition, criteria for measuring the performance of the equipment also remain unchanged from the days of monaural reproduction.

Matthew Polk is Chairman of the Board and Vice President/Engineering of Polk Audio, Baltimore, Md.

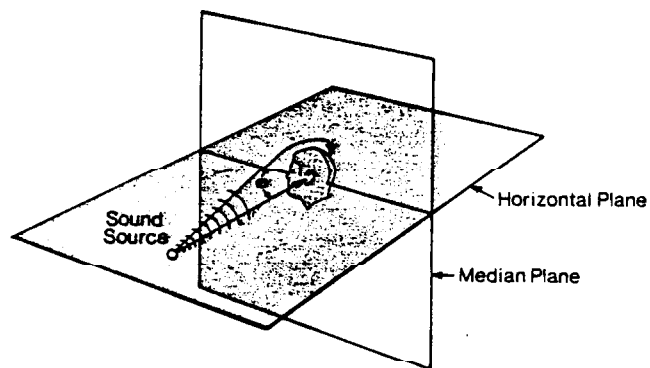

Fig. 1—Localization by Interaural Intensity Differences.

Mono Versus Stereo

Stereo is an essentially psychoacoustic phenomenon. That is, a listener is required for the sound localization process to take place. Early experimentation with reproduction of sounds in stereo revealed that the human hearing process perceived certain limitations in the sonic image produced by multiple speaker systems. Using essentially the same speakers as had been used in earlier mono systems, the sound field was perceived to be limited by the physical positions of the loudspeakers. Despite this limita-

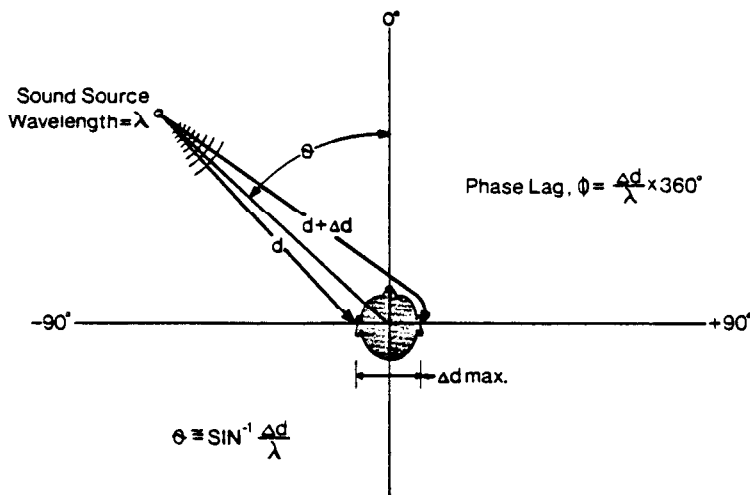

Fig. 2—Localization by Interaural Phase Differences.

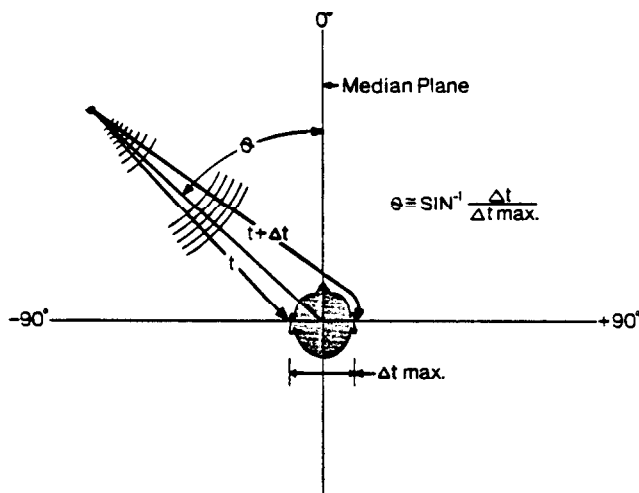

Fig. 3—Localization by Interaural Time Delay (ITD), where t is the time required for sound to reach the

nearest ear and Δt is the delay in reaching the other ear, also known as the Interaural Time Delay.

tion, stereo imaging was a great improvement over the monaural image, and stereo became an unqualified success. Once stereo was firmly established, attempts were made to present a more complete sound field, the most notable of these attempts being the ill-fated four-channel systems of the '70s. In the mid-'70s, several of us at Polk began to wonder whether it was necessary to use additional channels to create a more realistic sonic image. We could show that, in theory, there was enough information contained in two normal stereo channels

to define at least a 180° sound stage, and indications were that even more might be possible. This gave us confidence that a more complete sound stage might be reproduced from existing stereo recordings. Recognizing that the equipment being used to reproduce stereo was basically unchanged from monaural equipment, we saw that we would have to expand our concept of what the equipment was being asked to do. More than asking the equipment simply to reproduce an input signal, we proposed to make the equipment work with, rather

than against, psychoacoustic principles, to re-create a sound stage in the listener's mind.

Directional hearing is primarily a binaural process. In simplest terms, the brain compares the sounds heard by the two ears and uses the difference to determine the direction and distance of the sound source. The differences between the sounds at the two ears are perceived in three ways: Intensity, phase, and arrival time. (See Figs. 1 through 5.)

In each case, the listener uses two signals, one at each ear, to localize the sound source. However, a stereo system has two speakers, and will provide the listener with a total of four signals (see Fig. 7). The sound from each speaker that crosses the listener's head to the opposite ear is known as interaural crosstalk. Experimenters in directional hearing were the first to be troubled by interaural crosstalk since its existence prevents the independent control of phase and arrival time of sounds at each ear. Interaural crosstalk was also thought to be the primary cause for the limitations on stereo imaging. The obvious solution was, of course, to use headphones, thereby eliminating the interaural crosstalk sound paths. This was a very satisfactory means to an end for psychoacoustic research, but it was not as successful in the reproduction of music. Although the elimination of interaural crosstalk seemed to give significant advantages to headphones, the phones still failed to produce a convincing sonic illusion. Clearly, there were numerous questions still to be answered about the stereo imaging process before approaching the final question of how the reproducing equipment should interact with the listener to produce a believable sonic illusion.

It seemed natural to focus on the last link in the reproducing chain, the loudspeaker, in an effort to develop the necessary understanding and control of the stereo imaging process. The fact that two loudspeakers could produce a phantom image between them was well known; the basic mechanism is shown in Fig. 7. The major difficulty here is that the two speakers will provide the listener's ears with four signals, whereas only two can be properly used. To avoid confusion, the hearing mechanism selects only one of the two sounds at each ear, according to a principle known as the precedence ef-

fect. First described in 1949 by Helmut Haas, the precedence effect simply states that only the first arrival at each ear will be used for directional location (see Fig. 6). It is not difficult to apply this concept intuitively to the stereo listening situation shown in Fig. 7. If both speakers produce the same sound at the same time, the first sound to arrive at each ear will be the direct sound from the speaker on that same side. The second sound at each ear will be the interaural crosstalk signal which has been delayed by traveling the extra distance across the listener's head. Since the direct sounds arrive first, they will be the only ones considered, and since they arrive coincidentally, and with near-equal loudness, the listener will perceive a phantom sound source as if it were centered between the speakers.

Although this situation was easy to analyze intuitively, we realized that more complex cases would be easier to approach with an appropriate mathematical notation. Two quantities characterize each of the signals arriving at the listener's ears, arrival time and intensity. Ignoring any electrical delays, the arrival time of the sound will be proportional to the distance traveled in reaching the ear. Relative intensity is easily expressed as a ratio. So, the signals reaching the ears can be expressed as a function of the time required to reach the ear, multiplied by the sound intensity relative to that at the other ear.

Accordingly, the left and right loudspeaker signals were considered as functions of time. If the time required for the sound from the left loudspeaker to reach the left ear is t , that signal at the left ear would be written as $L(t)$. If the interaural time delay for the same signal to pass across the listener's head to the right ear is Δt , then the time required for the left signal to reach the right ear will be $t + \Delta t$. That crosstalk signal would then be written as $L(t + \Delta t)$. Using this notation, the signals at each ear in Fig. 7 will be:

$$\text{Right Ear} \\ R_e = R(t) + L(t + \Delta t) \quad (1a)$$

$$\text{Left Ear} \\ L_e = L(t) + R(t + \Delta t) \quad (1b)$$

From this point on, I will use Δt as the notation for the interaural time delay associated with the positions of the loudspeakers.

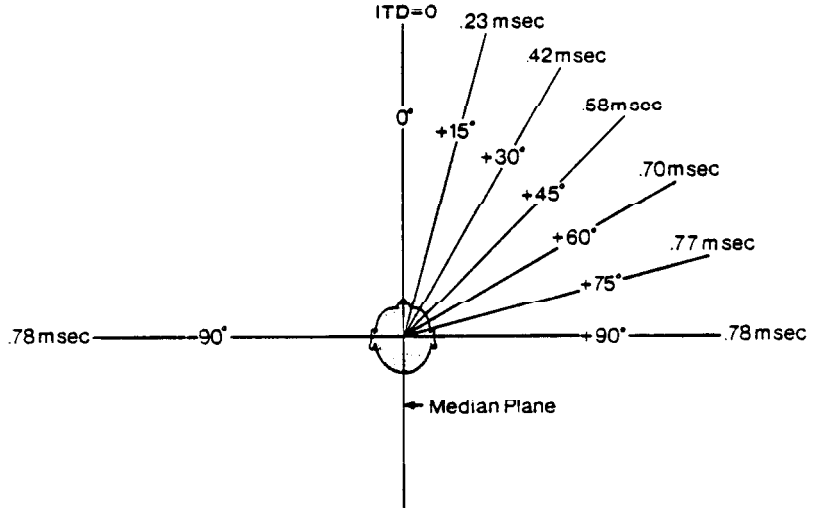

Fig. 4—Experimentally determined values for the interaural time delay for various angles of incidence.

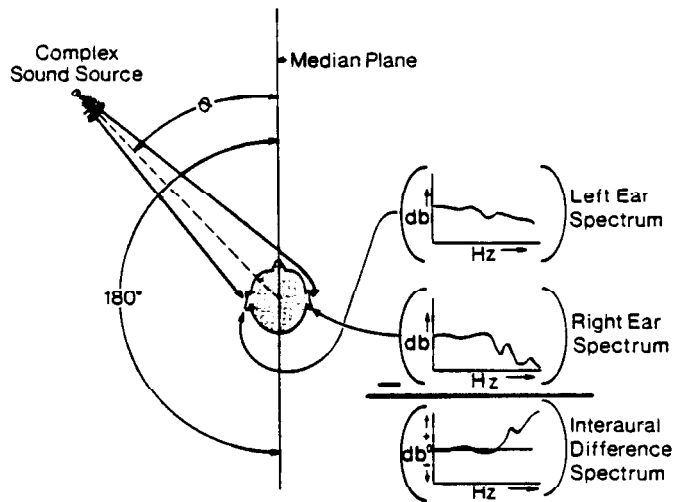

Fig. 5—The Interaural Difference Spectrum (IDS).

Interaural Crosstalk Distortion

Two speakers will produce a convincing center image—but what happens as the image moves to the side? In Fig. 7, each ear receives two signals, the direct sound followed by the interaural crosstalk signal (Eq. 1). Turning the right speaker off would represent the most extreme leftward shift of sonic image on the basis of interaural intensity difference. Only one signal at each ear would remain:

$$R_e = L(t + \Delta t) \quad (2a)$$

$$L_e = L(t) \quad (2b)$$

In the absence of a right-speaker signal, the crosstalk signal becomes the first right-ear arrival and causes the sound to be perceived as coming from the left loudspeaker. The same would happen on the other side if the left-channel signal were turned off. The presence of the interaural crosstalk signals effectively cuts off the sound stage at the loudspeaker positions.

Suppose that one channel is delayed relative to the other. This also will cause the sonic image to shift. If right is delayed by Δt relative to left, we have:

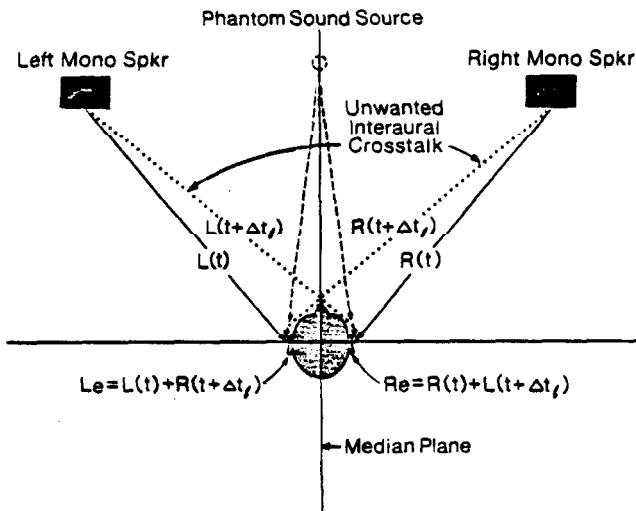
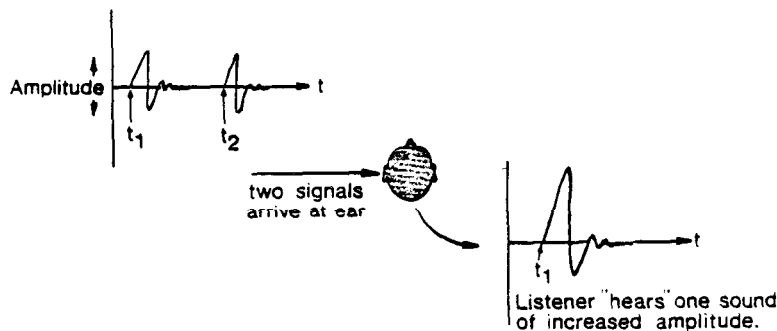

Fig. 7—Stereo localization of a phantom source. If left and right channels are of equal loudness and

leave the speakers at the same time, the sound will seem to originate directly between the speakers.

$$R_e = R(t + \Delta t) + L(t + \Delta t) \quad (3a)$$

$$L_e = L(t) + R(t + \Delta t + \Delta t) \quad (3b)$$

As the right-channel delay increases, the sonic image will shift progressively to the left. As long as the delay of the right channel, Δt , is less than the interaural delay, Δt_i , for the left-speaker crosstalk signal, localization will be controlled by the right-channel signal. When the right-channel delay exceeds the crosstalk delay, the interaural crosstalk signal will become the first arrival and will again limit the image shift to the position of the loudspeaker. It began to appear to us that the existence of the interaural crosstalk signals caused the stereo image to be linked more to the positions of the loudspeakers than to the musical content of the stereo signals.

Next, we tackled the problem of

headphones. Despite the fact that headphones eliminate interaural crosstalk, they still do not usually produce a convincing stereo image. We looked again at one channel delayed relative to the other. The signals at the ears for headphones were the same as those in Eq. (3), but without the crosstalk terms. Accordingly, for right delayed relative to left:

$$R_e = R(t + \Delta t) \quad (4a)$$

$$L_e = L(t) \quad (4b)$$

Assuming the left- and right-ear signals are of roughly equal intensity, localization of the sound will be entirely controlled by the time delay, Δt . The sonic image will shift to the left as the magnitude of the delay increases. When the delay becomes equal to the maximum naturally occurring interaural

time delay, Δt_{max} (see Fig. 3), the sonic image will be shifted all the way to the left. If the delay between channels increases further, what will happen? The image can shift no further! The directional hearing mechanisms are closely related to the physical dimensions of the head and ears. The maximum naturally occurring interaural time delay (ITD) corresponds to the distance between the ears, roughly 6 3/4 inches. If the apparent ITD presented by the headphones is increased to correspond to a distance of several feet, the listener cannot respond in any predictable way. It would be like trying to locate the direction of a sound while holding long cardboard tubes against each ear.

As we saw in Eq. (3), the interaural crosstalk signals produced by loudspeakers limit the side-to-side image shift. But, in doing so, they also prevent the problem of non-localizable sounds that occurs with headphones. In Fig. 8, sound sources A through F are shown being recorded by two microphones set the same distance apart as a person's ears. Loudspeakers tend to localize everything as being in front. This is because the positions of the loudspeakers forward of the listener, obviously, must create the appropriate frequency spectra at each ear for forward localization. The bottom half of Fig. 8 shows the apparent positions of the sounds when played back over two mono loudspeakers. Due to the limitations we have just discussed, the sonic images of sounds C through E will "pile up" in the same direction as the left loudspeaker while the sounds A and B will have distinct images between the speakers.

Although this piling up of sound images is observed on many recordings, the prediction that the image could spread no further than the loudspeaker positions was initially disturbing. Sometimes a single pair of loudspeakers can produce a sonic image which extends slightly outside the bounds of the speaker positions. We realized that in each case where we had observed this, the speakers were placed very close to the listener and had some unusual directional characteristics which, we speculated, were contributing to a partial elimination of interaural crosstalk sound paths. This was not a measurable phenomenon, but it opened our minds to the idea that interaural crosstalk could be eliminated by acoustic methods.

The Full Potential of Stereo

Although binaural recording techniques have produced startling results with headphones, our goal was to reproduce a more complete sound stage from existing stereo recordings. Binaural recordings being in regrettably short supply, we realized that, whatever system was devised, it would have to cope with the broad range of available recordings. Consideration of prevalent recording practices within the context of the directional hearing mechanisms had revealed that the sound imaging abilities of both loudspeakers and headphones were limited, but in different ways. The width of sound stage presented by loudspeakers is limited by interaural crosstalk. The stability of the sonic image of headphones is limited by the lack of realistic directional cues. This meant that we would have to do more than eliminate interaural crosstalk. In addition, we would have to find a way for the directional cues contained in the recordings, such as they are, to reach the listener's ears in a manner acceptable to the hearing process.

Rather than trying to imagine what nature of speaker system might do all of these things and still sound good, it seemed more appropriate to try to capture our needs in mathematical notation. We wanted a system which, when balanced all to one channel, would provide the listener with a sonic image directly to the side, at 90°, but which would remain stable regardless of the interchannel delay. The signals required for a left-side signal would be:

$$R_e = R(t) \quad (5a)$$

$$L_e = R(t + \Delta t_{max}) \quad (5b)$$

Conversely, a right-side signal would be:

$$R_e = L(t + \Delta t_{max}) \quad (6a)$$

$$L_e = L(t) \quad (6b)$$

Adding these will give the more general case for both channels operating:

$$R_e = R(t) + L(t + \Delta t_{max}) \quad (7a)$$

$$L_e = L(t) + R(t + \Delta t_{max}) \quad (7b)$$

The second term at each ear looks very much like a crosstalk signal with an ITD equal to Δt_{max} , but in reality it is sort of a stabilizing dimensional signal which limits the perceived ITD to values within the naturally occurring range.

A Directional Hearing Primer

Directional hearing works mainly by comparing the sounds heard by the two ears of a listener. Specifically, three quantities are compared: intensity, phase, and arrival time. A sound arriving from one side of the head will be partially blocked in reaching the ear on the other side, giving rise to a difference in loudness between the two ears (see Fig. 1). The precise difference created depends both on the angle of incidence of the sound and on the frequency. The unique combination of loudness difference and frequency is linked to the angle of incidence of the sound in the horizontal plane. High frequencies are blocked more easily by the head, leading to greater loudness differences.

Intensity differences also play a role in locating complex sounds. For a given angle of sound incidence, each frequency has its own characteristic loudness difference. The sum of these will create an interaural difference spectrum (IDS) which corresponds to a specific angle of incidence (see Fig. 5). The exact characteristics of these difference spectra enable the listener to distinguish between sounds coming from the front and sounds coming from the rear.

In addition, the hearing mechanism is sensitive to the difference in relative phase of a sound which appears at both ears, though this is limited to continuous tones. A sound arriving from one side of the head experiences a time delay in reaching the farther ear. The listener senses an interaural phase difference which depends on the angle of incidence of the sound and on the frequency (see Fig. 2). However, for higher frequencies, the phase lag may become greater than 180° and hence indistinguishable from a phase lead in the opposite direction. Appropriately, the hearing mechanism is relatively insensitive to phase differences above 900 Hz, a frequency whose half-wavelength is nearly equal to the interaural distance.

Transient sounds are localized mainly on the basis of the difference in arrival time at the two ears. Since most naturally occurring sounds are transient, this is both the most impor-

tant and most accurate method of directional location. The interaural time difference (ITD) increases roughly as the sine of the angle of sound incidence up to 90° left or right of the median plane. At this point the sound must travel entirely across the head to reach the far ear, and the ITD becomes equal to Δt_{max} (see Fig. 3). Figure 4 shows experimentally determined values of ITD versus angle of incidence.

Finally, two related mechanisms, forward masking and the precedence effect, help the listener to discriminate between the many sounds reaching the ears at any given time (see Fig. 6). Basically, if two similar sounds of equal loudness arrive at one of the listener's ears separated by a short period of time, the listener will hear only one sound but of greater loudness than either of the individual sounds. The maximum interval for forward masking of musical sounds in a live room is about 35 mS. However, the maximum interval for masking of test clicks over headphones may be as low as 3 mS. The precedence effect is observed in the case of two signals at each ear, where the perceived direction of the sound source will be determined on the basis of the arrival of the first sound at each ear.

An example of phantom source localization from two speakers is shown in Fig. 7. Here, each ear receives two signals, one from each speaker. However, due to the precedence effect, only the first sound at each ear is considered. These are the direct sounds from each speaker, labelled L(t) and R(t). If the listener is centered between the speakers, these sounds will arrive at the same time. If they are also of approximately equal loudness, a phantom sound source will be perceived midway between the speakers.

In practice, most stereo image location takes place on the basis of intensity differences. This is due to the existence of interaural crosstalk signals which restrict the possible range of interaural time delays. As shown in Fig. 8, the location of phantom sound sources is limited to within the loudspeaker positions. M.P.

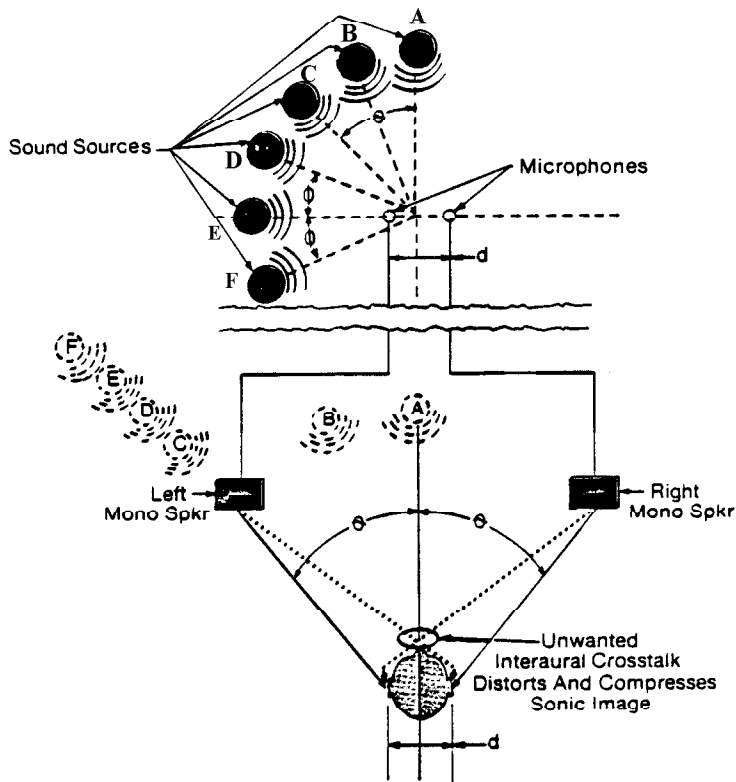

Fig. 8—Normal stereo imaging with sounds recorded by two microphones at locations A through F. When reproduced by two mono

loudspeakers, the existence of interaural crosstalk will limit the phantom images to the locations shown in the lower half.

At this point, we made a decision that the sound sources, whatever they might be, should be placed in a forward position relative to the listener. This would eliminate the need for any complicated filtering to replicate the necessary interaural intensity differences for forward localization of sounds. However, if the sound sources were loudspeakers we would again be limited by the existence of interaural crosstalk signals. If we include the crosstalk signals in the expressions for the idealized signals above, we then have:

$$R_e = R(t) + L(t + \Delta t) + L(t + \Delta t_{max}) \quad (8a)$$

$$L_e = L(t) + R(t + \Delta t) + R(t + \Delta t_{max}) \quad (8b)$$

The second term at each ear is the crosstalk signal, which arrives earlier than the desired dimensional signals represented by the third terms. In order to take advantage of the later-arriving dimensional signals, the crosstalk signals would have to be eliminated or substantially reduced in loudness. Recalling that we had observed partial

elimination of crosstalk signals due to unusual directional characteristics, and recalling the well-known phenomenon of low-frequency cancellation between two out-of-phase speakers, we guessed that it might be possible to acoustically cancel the interaural crosstalk signals. If this were done, the signals at the ears would be:

$$R_e = R(t) + L(t + \Delta t) - L(t + \Delta t') + L(t + \Delta t_{max}) \quad (9a)$$

$$L_e = L(t) + R(t + \Delta t) - R(t + \Delta t') + R(t + \Delta t_{max}) \quad (9b)$$

The new third term in each expression should be thought of as a phase-inverted equivalent of the crosstalk signal, timed to arrive at the correct ear at the same time as the original crosstalk signal. This was a very attractive idea, but we were not at all sure how it would be accomplished.

Timing the Delay

In order to cancel the crosstalk, a phase-inverted version of the sound

could be acoustically delayed to arrive at the proper ear at the precise time to cancel the crosstalk signal. Creating the acoustic delay is no great trouble—you simply place the sound source farther away. It immediately seemed that if we had two pairs of acoustic sources, it would be possible to do this; the idea was to use one pair to cancel the crosstalk produced by the other. The cancellation source would have to be the same distance from the ear where the cancellation was to occur as the main source whose crosstalk signal was to be cancelled. In addition, the cancellation source should be placed so as to minimize cancellation of the direct sound reaching the other ear. Figure 10 shows an arrangement of drivers which allows the proper cancellation to take place. The signals arriving at the two ears for this arrangement would be:

$$R_e = R(t) + L(t + \Delta t) - L(t + \Delta t') - R(t + \Delta t' + \Delta t) \quad (10a)$$

$$L_e = L(t) + R(t + \Delta t) - R(t + \Delta t') - L(t + \Delta t' + \Delta t) \quad (10b)$$

Here $t + \Delta t'$ is the time required for the sound from the cancellation drivers to reach the nearest ear. So long as $\Delta t'$ is equal to Δt , the main driver crosstalk signals (second term) will be cancelled by the direct sound from the cancellation drivers (third term). The fourth terms are the crosstalk signals generated by the cancellation speakers themselves. For each ear they are the same signal as the direct sound from the main driver (first term), but arrive considerably later. Due to the precedence effect, they will not interfere with the localization process.

The placement of drivers shown in Fig. 10 also answered the requirement that the listening position be flexible. The center-to-center distance between the main and cancellation drivers on each side is the same as the distance between a person's ears, roughly 6¾ inches. As long as the listener remains on the axis between the two speakers and the cabinets face straight forward, sound from the cancellation drivers will arrive at the proper time to cancel the crosstalk signals regardless of how close or far away the listener sits. The remaining problem with this arrangement, however, was the lack of the stabilizing dimensional signals necessary to prevent the type of non-localizable sounds that can occur with head-

phones. Consider the effect of having no right-channel signal on this system:

$$R_e = L(t + \Delta t) - L(t + \Delta t') = \text{nothing} \quad (11a)$$

$$L_e = L(t) - L(t + \Delta t' + \Delta t) \quad (11b)$$

In nature, a sound is not normally heard in one ear only, and, presented with such a situation, a listener would not be able to assign an accurate direction to the sound. The solution to this problem was to use a stereo difference signal as both the dimensional and the cancellation signal. The difference signal has long been known to contain mostly ambient information, but in this case, we recognized that its components represented the two signals that we needed. The $R - L$ signal was fed to the right dimensional/cancellation driver, and the inverse signal, $L - R$, was fed to the left dimensional/cancellation driver. In each case the positive portion of the difference signal is the stabilizing dimensional signal, while the negative portion is the cancellation signal. The entire system is shown in Fig. 11. The resulting signals at each ear would be:

$$R_e = R(t) + R(t + \Delta t') + L(t + \Delta t) - L(t + \Delta t') - R(t + \Delta t' + \Delta t) + L(t + \Delta t' + \Delta t) \quad (12a)$$

$$L_e = L(t) + L(t + \Delta t') + R(t + \Delta t) - R(t + \Delta t') - L(t + \Delta t' + \Delta t) + R(t + \Delta t' + \Delta t) \quad (12b)$$

Writing these out in plain language, without reference to the particular speakers, we have:

(Signals arriving at the ear) = (main driver direct signal) + (dimensional driver direct signal) + (main driver crosstalk signal) - (dimensional driver direct signal) - (dimensional driver crosstalk signal) + (dimensional driver crosstalk signal).

In all, each ear receives six signals. For clarity the equation has been labelled to indicate the driver from which the signals originate. Crosstalk signals break the median plane in reaching the ear in question, whereas the direct signals do not. The various time delays are defined as follows:

t = time required for sound from main driver to reach nearest ear.

$t + \Delta t'$ = time required for sound from dimensional driver to reach nearest ear.

Δt_t = ITD for main driver crosstalk sound to reach opposite ear.

$\Delta t'$ = ITD for dimensional driver

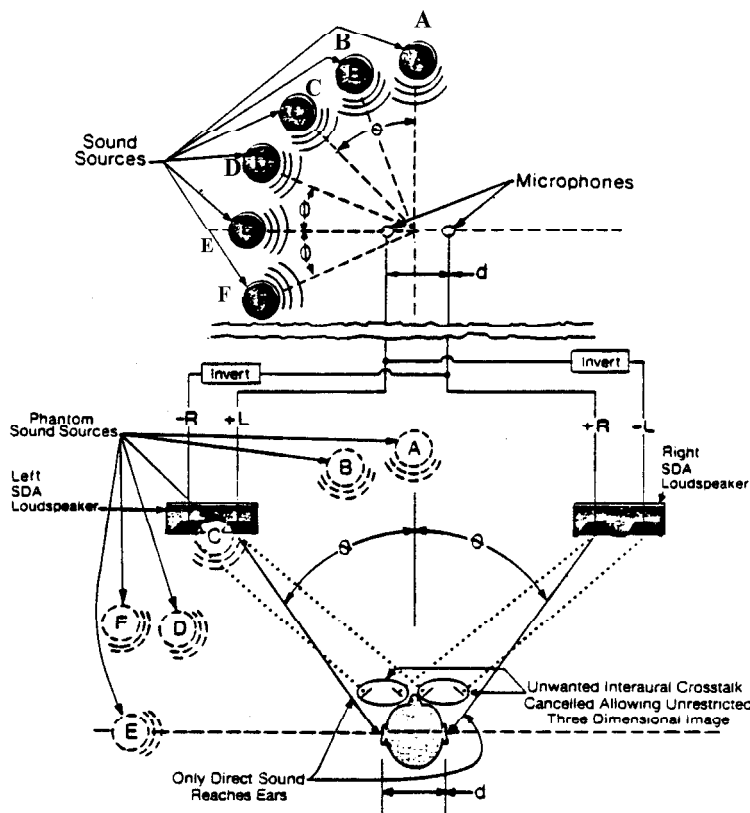

Fig. 9—Stereo dimensional imaging. If the interaural crosstalk signals are cancelled, the stereo stage will be unrestricted, allowing proper imaging

of sound sources A through E. Sound source F will still be ambiguously located due to the lack of front-to-back directional cues.

crosstalk sound to reach opposite ear. Δt_{max} = the maximum naturally occurring ITD.

At this point it appears helpful to explain each term. Term 1: The direct sound from the main driver will be the first arrival at the ear and will be the primary sound used by the localization process when the sonic image shifts for sounds on that side. Term 2: The positive component of the direct sound from the dimensional driver. Since it is the same signal as the first term, but arrives later, it will always be ignored by the localization process. Term 3: The main driver crosstalk signal; if it were not cancelled, it would limit the width of the sonic image. Term 4: The inverted component of the direct sound from the dimensional driver, otherwise known as the cancellation signal. It arrives coincidentally with the main driver crosstalk signal and cancels it. Term 5: The inverted portion of the dimensional driver crosstalk signal is also a late arrival and will be ignored in the localization process. Term 6: The positive portion of the dimensional

driver crosstalk signal, or dimensional signal; it insures a stable sonic image by placing an upper limit on the possible values of perceived ITD generated by the system.

Now, if we turn off the right channel sound as we did in Eq. (11), keeping in mind that for this arrangement $\Delta t'$ equals Δt , the signals at the two ears are:

$$R_e = L(t + \Delta t) - L(t + \Delta t') + L(t + \Delta t' + \Delta t) = L(t + \Delta t' + \Delta t) \quad (13a)$$

$$L_e = L(t) + L(t + \Delta t') - L(t' + \Delta t' + \Delta t) \quad (13b)$$

With signals at both ears, the listener will have no trouble localizing the direction of the phantom sound source. The perceived ITD will be the sum of $\Delta t'$ and Δt , which will produce a phantom image well outside the speaker positions as shown in Fig. 11.

The Stereo Dimensional Loudspeaker

The stereo dimensional speaker system described here in theoretical

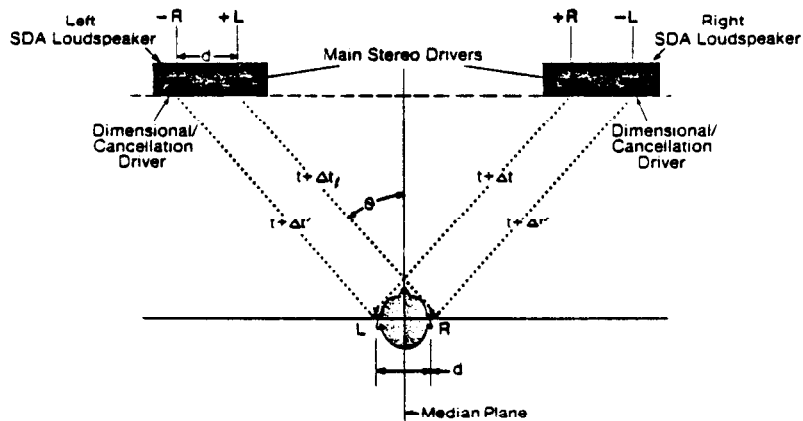

Fig. 10—Geometry for providing flexibility of listener location. Cancellation drivers are placed at the interaural distance from the main drivers and just outside them. The left cancellation driver receives the

inverted right signal and vice versa. Proper cancellation of interaural crosstalk will occur for any location on the central axis between the speakers.

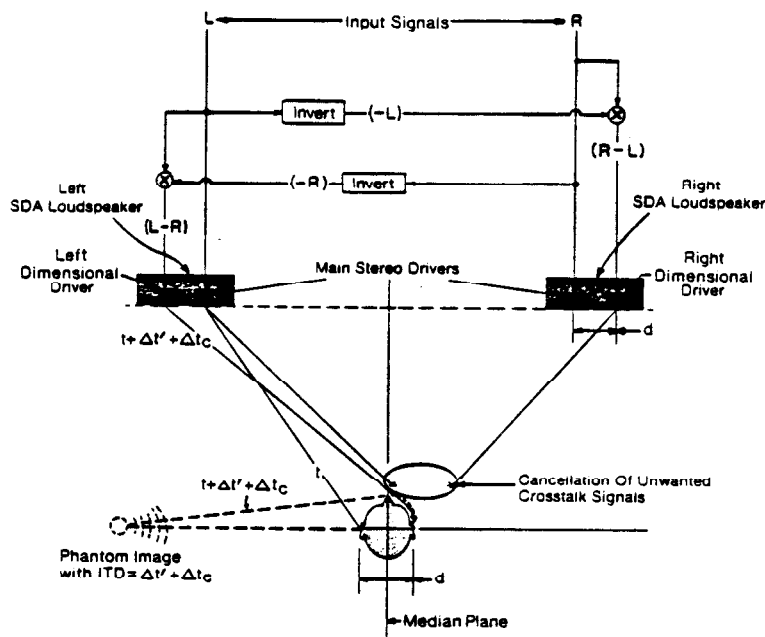

Fig. 11—Block diagram of complete stereo dimensional speaker system. Use of stereo difference signals at the cancellation drivers provides necessary image stabilization cues

and limits the induced ITD of the system to naturally occurring values. Optimum sound-stage width occurs when the listener forms an equilateral triangle with the speakers.

of the driver arrays on each side, which fixed the geometrical relationship between them. The left and right speaker cabinets were interconnected with a cable to provide the components of the stereo difference signal to the dimensional drivers, and a complex crossover matrix was designed to provide the correct frequency response for each array as well as the critically important phase relationships between them. As soon as the prototypes had been debugged, we hooked them up to some music. It was immediately apparent to us that the idea was a success.

As each set of prototypes was completed, tested and evaluated, more unsuspected pieces of information were uncovered. The finished system shown in Fig. 12 contains many important features discovered during the refinement process. For example, phase matching between the main and dimensional arrays was found to be necessary at surprisingly low frequencies, well below 100 Hz. As a result, the main and dimensional drivers of the finished system share the same acoustic volume, ensuring that they will see identical acoustic loading. However, the most significant realization coming out of the refinement process was of the complete inadequacy of our existing measurement techniques to assess the performance of this system. Although we have since made considerable progress in developing a more relevant measurement system, the human ear remains our most discriminating design tool.

Audible Benefits

The finished system, in many respects, has exceeded our expectations. The flexibility of listening position is greater than was expected, allowing not only front-to-back movement, but substantial side-to-side tolerance as well. Analysis of signals at the ears for listening locations off the central axis somewhat justifies this, but predicts a more dramatic image shift than the "changing seats in a concert hall" effect actually observed. More easily explained is the observation that phantom sources localized to the sides seem to remain stationary as the listener moves away from the system, rather than moving with the listener. As we recall from Fig. 11 and Eq. (13), the perceived ITD will be the sum of $\Delta t'$ and Δt_i . Due to the geometry of the system, this quantity will decrease as

terms seems to offer all that we had hoped for. Using the theory we had developed as a guide, we set about constructing prototypes of what we hoped would be the first loudspeaker system capable of realizing the stereo imaging and dimensional capacity of available program material. The prototypes were constructed with four identical sets of drivers for the main and

dimensional arrays. The Polk 6½-inch mid-woofer was used since its size allowed, precisely, for the interaural spacing of 6¾ inches required between the main and dimensional arrays on each side. In addition, the wide frequency response of the driver would cover most of the frequency range crucial for directional location. We constructed a single cabinet to house both

the listener moves away, causing the sound stage to narrow and preserving the perspective of greater distance. Less explainable, however, is the experience of having some sounds seem to actually originate from the rear of the listening area. Since this occurs primarily on pop recordings, we can only speculate that the recording studio has inadvertently created an interaural difference spectrum appropriate for rearward localization. Nevertheless, the effect is startling.

The newly designed Polk SDA systems are, we think, the world's first true stereo loudspeakers, strongly realizing the capabilities of the stereo medium. The unique ability of the system to place sonic images over an unrestricted stereo stage allows the listener to hear the recorded instruments or vocalists firmly located in the original acoustic environment. In addition, due to the system's preservation of directional information, each sound becomes better separated and more distinct. Crucial to the accomplishment of these sonic goals has been the elimination of interaural crosstalk by effectively cancelling the sounds indicating the loudspeaker positions and replacing them with the correct directional signals for the recorded sounds. **A**

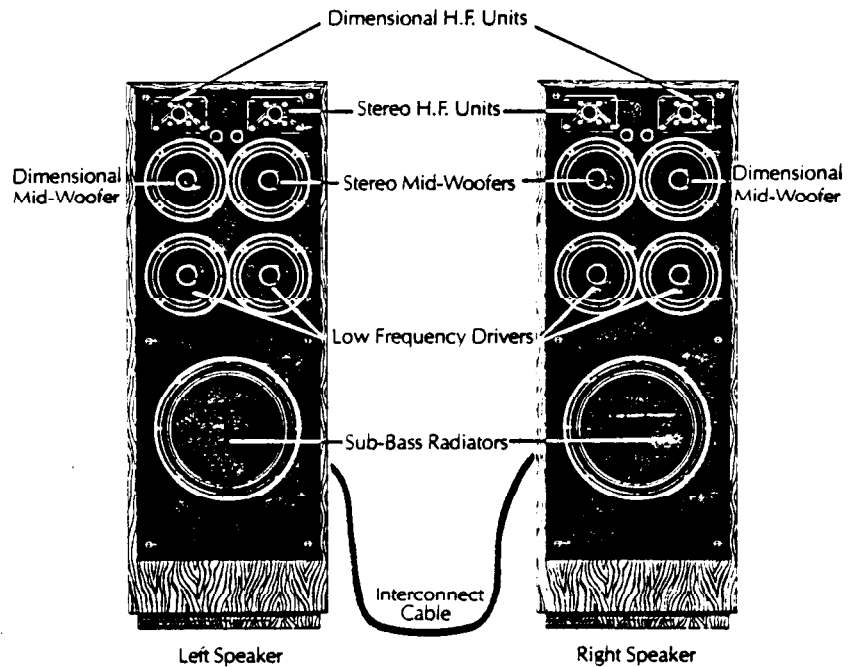

Fig. 12—Physical configuration of the finished system. The four tweeters and four upper 6½-inch mid-woofers form the main and dimensional driver arrays. The inside array in each

cabinet is the main array, while the other is the dimensional array. The two lower 6½-inch drivers, together with the passive radiator in each cabinet, operate below 75 Hz.

Bibliography

1. Gatehouse, R. Wayne, ed., *Localization of Sound: Theory and Applications*, Amphora Press (Box N, Groton, Conn. 06340), 1982.
2. Stevens, Stanley S. and Hallowell Davis, M.D., *Hearing: Its Psychology and Physiology*, Acoustical Society of America, 1938; reprinted 1983.
3. Bonade, Arthur H., *Fundamentals of Musical Acoustics*, Oxford University Press, New York, 1976.
4. Abel, Sharon M. and Hans Kunov, "Lateralization Based on Interaural Phase Differences: Effects of Frequency, Amplitude, Duration, and Shape of Rise/Decay," *Journal of the Acoustical Society of America*, March 1983, pp. 955-960.
5. Hartman, W. M., "Localization of Sound in Rooms," *JASA*, Nov. 1983.
6. Snow, William B., "Basic Principles of Stereo Sound," *Journal of the Society of Motion Picture and Television Engineers*, Nov. 1953.
7. Wallach, Hans et al., "The Precedence Effect in Sound Localization," *Journal of the Audio Engineering Society*, Dec. 1973.

8. Haas, Helmut, "The Influence of a Single Echo on the Audibility of Speech," *JAES*, reprinted March 1972.
9. Fay, Richard and George Gourevitch, eds., *Hearing and Other Senses: Presentations in Honor of E. G. Wever*, Amphora Press, Groton, Conn., 1983.
10. Buijss, J. H., "Binaural Recordings and Loudspeakers," *Wireless World*, Nov. 1982.
11. Hirata, Y., "Improving Stereo at Low Frequencies," *Wireless World*, Oct. 1983.
12. Willocks, M. and G. Badger, "Surround Sound in the Eighties—Localization and Psychoacoustics," Preprint No. 2029 (H7), 74th AES Convention, Oct. 1983.
13. Bauck, J. L. and D. H. Cooper, "On Acoustical Specification of Natural Stereo Imaging," Preprint No. 1649 (H7), 66th AES Convention, May 1980.
14. Goldmark, P. C. and J. M. Hollywood, "Psychoacoustics Applied to Stereo Reproduction Systems," *JAES*, April 1959.
15. Egan, James P. et al., "Some Factors Affecting Multichannel Listening," *JASA*, Sept. 1954.

16. Sandel, T. T. et al., "Localization of Sound from Single and Paired Sources," *JASA*, Sept. 1955.
17. Haffer, E. R. et al., "Detection of Interaural Differences of Intensity in Trains of High Frequency Clicks . . .," *JASA*, May 1953.
18. Penfold, R. A., "A Headphone Listening Enhancer," *Hi-Fi News*, Aug. 1982.
19. Hodges, Ralph, "Multi-Channel Listening," *Stereo Review*, April 1971.
20. Feldman, Leonard, "On Matrix Quadraphonic Systems," *Audio*, Oct. 1971.
21. Lawrence, Chester H., "4-Channel Adapter Roundup," *Radio-Electronics*, March 1972.
22. "Four-Channel Stereo," *High Fidelity*, Jan. 1971.
23. Kampel, I. J., "Living with Surround Sound," *Hi-Fi News*, Jan. 1971.
24. Gerson, Michael, "Surround Sound from 2-Channel Stereo," *Hi-Fi News*, Aug. 1970.
25. Gerson, Michael, "A Year of Surround Sound," *Hi-Fi News*, Aug. 1971.
26. Hafler, David, "Two Channel Quadraphony," *Hi-Fi News*, Aug. 1970.

Appendix 2

SL3000 Tweeter Technical Paper

This paper was originally published in September of 1989 by Polk Audio. It provides a thorough technical discussion of the development and characteristics of the SL3000 tweeter. The SL2000, the tweeter used in the SDA SRS series prior to the SL3000, had a 5 dB resonance at 13,000 Hz. The SL3000 solved that problem and resulted in flatter, more accurate treble response. Although none of the other SDA series speakers were retrofitted with the SL3000 tweeter, it was used in the RTA 15TL and RTA 11TL loudspeakers.

The Polk Speaker

Technical Information from Matthew Polk and the Design/Engineering Team



Figure A

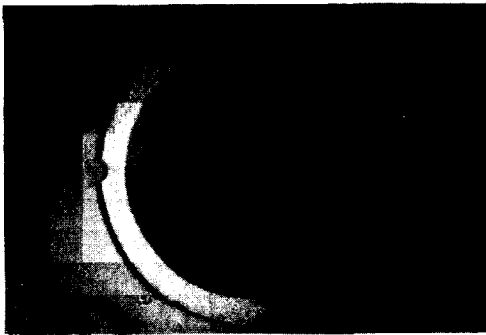

Dome moving as a piston without break-up



Dome exhibiting standing wave break-up at 14 kHz

Over two years ago, the Polk Audio Engineering staff was presented with our stiffest challenge. We were charged with the task of developing the world's best 1 inch dome tweeter. Our objectives were:

- Set a new standard for flatness of frequency response
- Extend frequency response, free of resonant peaks, to beyond 25 kHz
- Improve high frequency dispersion
- Set new standards for clarity and detail
- Dramatically increase power handling
- Extend low frequency response to below 1.5 kHz
- Maintain phase linearity over the entire 4 octave range of the device
- Maintain the high efficiency of previous Polk tweeters

Laser Interferometry Research

Working in concert with The Johns Hopkins University Center for Non-Destructive Testing, we began to extensively test various tweeter designs and dome materials using an advanced technique called Laser Interferometry. In this process, laser light is reflected from a moving dome, combined with light coming directly from the laser and then focused on a photographic plate. The resultant photograph is a hologram of the dome wherein the areas of the diaphragm which are in motion appear dark while the still or lessor moving areas appear light. Hence a dome with perfect pistonic motion would appear as a single dark object and standing waves would appear as alternating light and dark rings (See figure A).

Standing Waves Versus High Frequency Extension

Dome tweeters, characteristically, have either a peak in response somewhere in the top octave or a roll-off above 12 to 15 kHz (for a 1" dome). Through the use of laser interferometry we were able to link these two characteristics to a common phenomenon. In virtually all 1 inch soft dome tweeters a standing wave was observed on the surface of the dome, usually in the 12 to 15 kHz frequency range. This standing wave phenomenon, if untreated, led to a peak in the response at the same frequency. However, if sufficient damping material is added to the dome to control the standing wave resonance, output above that frequency drops off rapidly.

Another insight gained from the laser photographs of the moving surface of the dome was that only the very small portion of the dome directly connected to the voice coil is in motion at the highest audio frequencies. The rest of the dome surface is essentially motionless at these frequencies. The fact that only a very small percentage of the dome surface is producing sound at high frequencies helps to explain the large variations in high frequency response caused by small changes in the quality of the dome materials, alignment of voice coil to dome, amounts of glue used and amount of damping material applied.

We realized that both of these phenomenon depend on the stiffness of the dome material and on the way in which the dome is being driven by the voice coil. The greater the stiffness of the dome, the higher the frequency of the standing wave resonance. The more efficient the connection between the dome and voice coil, the greater the efficiency of high frequency reproduction and high frequency extension.

The Trilaminate Dome: Stiffness with Low Mass and Excellent Damping

In our efforts to produce a stiffer dome, we evaluated a wide range of materials including hi-tech composites such as carbon-fiber and kevlar; exotic metals such as titanium, stainless steel and various alloys; and coated films such as diamond and graphite on Kapton, as well as various vapor deposited coatings. In each case we found that materials stiff enough to push the standing wave resonance above the audible range had far too much moving mass to produce sound efficiently at high frequencies. Very thin low-mass diaphragms made from these materials proved impractical to fabricate in some

cases. In others, particularly the metal domes, they were found to be prone to unpredictable 'oil can' resonances when made thin enough to obtain adequate efficiency.

We reasoned that a combination of thin stiff layers of materials laminated to a material having good internal loss (damping) characteristics would give the best results. The material we identified as having the best internal loss characteristics is the special polyamide formulation used in our SL 2000 dome tweeter. However, the only process then available for applying the very thin stiffening layers operated only at temperatures above the melting point of polyamide. This significant problem was not overcome until the recent development of a low-temperature vapor deposition technique. This patented technique allowed us to evaluate the performance of a wide variety of stiffening layers. Ultimately, the best performance was obtained from one layer each of stainless steel and aluminum applied directly to the polyamide (See figure B). The unusual glassy appearance of the new dome arises from the fact that each metal layer is only as thick as a few wavelengths of light, thereby creating an optical interference filter effect similar to that used for optical experiments in space. The new dome is observed to be

Figure B

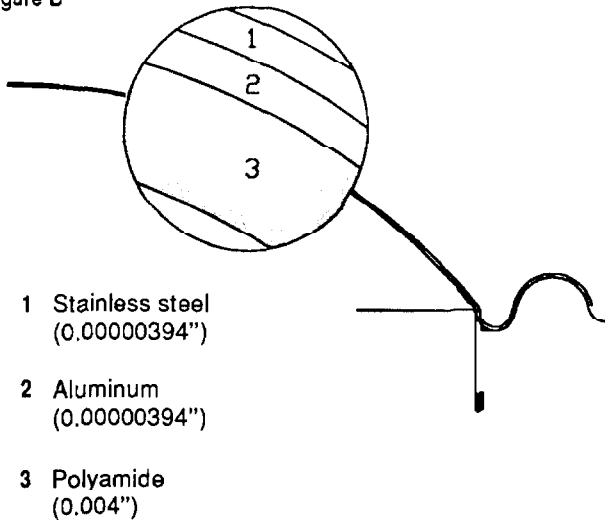
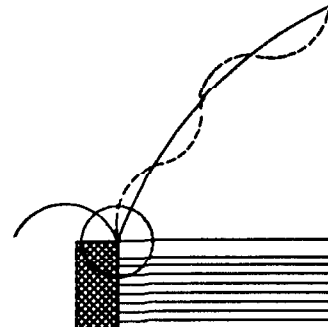
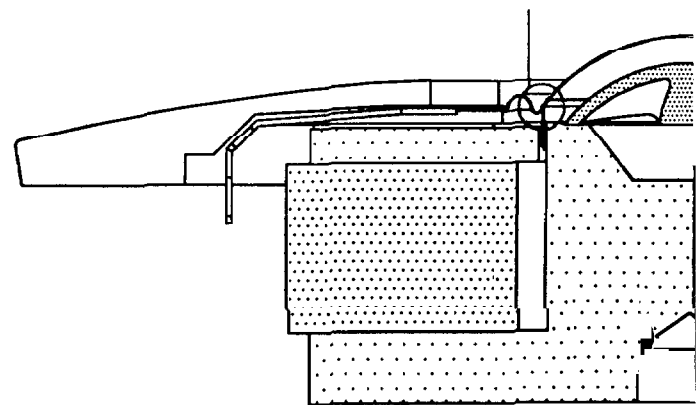

Figure C



Typical voice coil/dome interface with resultant standing wave distortion

Figure D



SL3000 Tweeter

stiff enough to push the standing wave resonance well beyond 20 kHz; light enough for high efficiency; and has sufficient internal losses to prevent breakup or ringing.

High Efficiency Drive System

To make best use of the new dome material and increase the surface area being utilized at high frequencies we needed a more efficient method of coupling the voice coil to the dome. We realized that much of the problem was caused by a 'hinging' effect at the tiny surface area where the voice coil meets the dome (See figure C). The situation is like cracking a whip. Your wrist acts as a hinge allowing you to create a standing wave traveling down the whip. If you stiffen your wrist, it becomes much more difficult to create the whip action which is analogous to the standing wave in the dome.

Our solution was to develop a voice coil former whose top section is preformed to follow the contour of the dome (See figure D). This High Efficiency Drive System pushes the dome over ten times more of its surface area than typical voice coils. In this way, a very stiff connection is created which virtually eliminates the whip action in the dome and allows high output to beyond 25 kHz.

Figure D

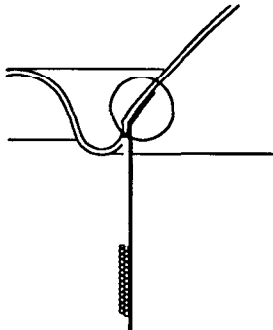

SL3000 High Frequency Drive System with 10x contact area

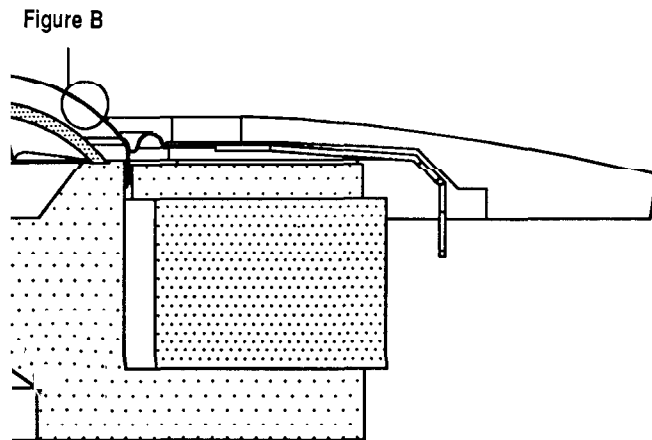

ross Section

The combination of the Trilaminare dome material and the new High Efficiency Drive System enable the SL 3000 to operate smoothly and predictably to beyond 25 kHz without resonance, at high efficiency and with improved transient response and dispersion.

ULV Magnetic Fluid

In order to provide cooling of the voice coil, thus enhancing reliability, previous tweeter designs have used ferromagnetic fluids in the gap. Until recently, these fluids were so viscous (syrupy) that they tended to reduce efficiency and degrade transient response. Ultra Low Viscosity (ULV) magnetic fluid used in the Polk SL 3000 is nearly as thin as water and promotes free coil excursion. This fluid cooling, along with low loss, silver-bronze braided lead out wire allows the SL 3000 to operate at over two times normal power and acoustic output levels without degradation of performance.

Critically Tuned Air Chamber

If a tweeter is not designed from the ground up to use magnetic fluid, its performance may suffer, particularly in efficiency and the lower part of its operational range. The reasons for this are apparent in looking at a cross-section of the tweeter. Without magnetic fluid the three volumes of air, under the dome, under the surround, and inside the magnetic structure, are connected. Air can flow relatively easily between them. When magnetic fluid is introduced into the gap, it isolates these three small air spaces and causes them to act like three independent acoustic compliances, thereby limiting low frequency performance (See figure E).

Figure E

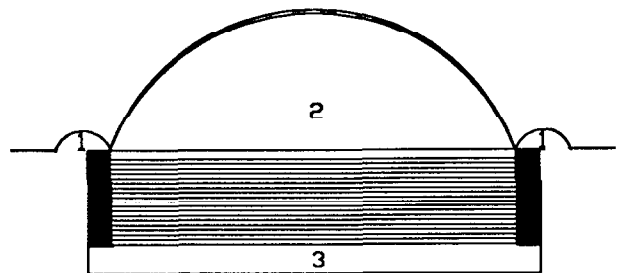

Cross section of typical magnetic fluid equipped tweeter showing three isolated air masses

Our solution was to create a large cavity in the pole piece and tune it much like a speaker enclosure is tuned for ideal bass (See figure F). In this way we were able to extend the low frequency limit of the SL 3000 to 1.2 kHz, thereby insuring seamless blending with our 6 1/2 inch driver.

Vented Damping Plug

As a woofer/cabinet system needs internal damping material (fiberglass, dacron, etc.) to absorb the rear radiation of the driver, we devised an integral damping plug which absorbs the rear radiation of the dome, thereby eliminating the distortions and phase anomalies which would result when the back wave bounced off the metalwork and back through the dome (See figure F). Special vents, cut into the damping plug allow air to flow in and out of the tuned chamber.

Figure F

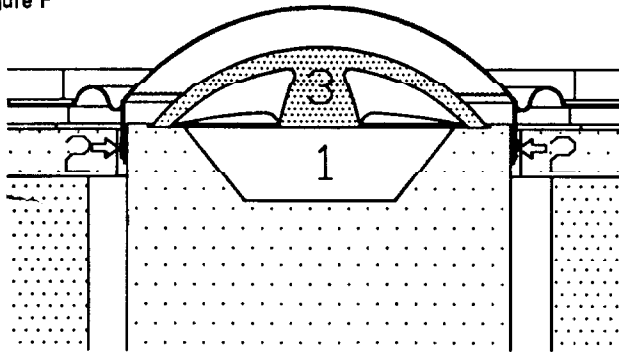

Cross section of Polk SL3000 showing:

1. Critically tuned air chamber
2. Magnetic cooling fluid
3. Vented damping plug

Audible Benefits

After nearly two years of effort, the research phase of the SL3000 project was complete. Our measurements showed that we had achieved our performance goals. In fact, we were confident that we had set new standards in respect to bandwidth, flatness of response (see figure G), phase linearity and power handling. But would these technical benefits translate to superior audible performance? Would the technology serve the music?

It was decided to introduce the SL3000 in our best speaker, the SRS 1.2. Immediately we heard dramatic, though expected, sonic benefits; high frequencies were smoother, extended and more detailed. What surprised us were the improvements in sound quality in frequencies **below** those reproduced by the tweeter. Voices and mid-range instruments were stripped of all coloration and inner detail was vastly improved.

Research showed that frequency response peaks in a tweeter draw the listener's attention, thereby masking detail in the mid-range. Additionally, by changing the harmonic structure, tweeters with resonant peaks create colorations in low and mid-frequency fundamentals.

Listen to the SRS 1.2TL and SRS 2.3TL (the 'TL' stands for Tri-Laminate). We're certain you will immediately appreciate their freedom from coloration, their ability to resolve the smallest details, and their musicality. Oh yes, play them loud.....real loud.

Figure G

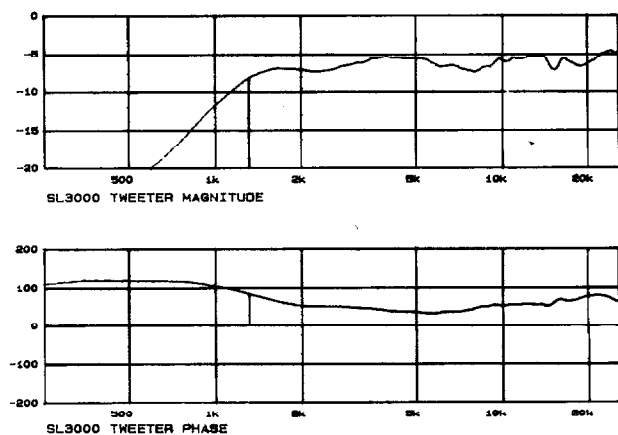

Frequency response (upper curve) and phase response (lower curve) of Polk SL3000 tri-laminate tweeter

polkaudio
 The Speaker Specialists®
 5601 Metro Drive
 Baltimore, MD 21215

Appendix 3

SDA Crossover Schematics and Wiring Diagrams

This appendix contains crossover schematics for the entire SDA Series manufactured from 1982 to 1991.

1. SDA CRS
2. SDA CRS+ (1986)
3. SDA CRS+ (1989)
4. SDA CRS+ (1989 – SL3000 modification)
5. SDA 2
6. SDA 2A
7. SDA 2B (1987)
8. SDA 2B/SDA CRS+ (1987-polyswitch change)
9. SDA 2B (1989)
10. SDA 2B Right Channel Wiring Diagram (1989)
11. SDA 2B Left Channel Wiring Diagram (1989)
12. SDA 1
13. SDA 1A
14. SDA 1B
15. SDA1C
16. SDA 1C Left Channel Wiring Diagram (1989)
17. SDA 1C Right Channel Wiring Diagram (1989)
18. SDA SRS 3.1TL
19. SDA SRS 2 (1986)
20. SDA SRS 2 (1987)
21. SDA SRS 2.3
22. SDA SRS 2.3TL
23. SDA SRS
24. SDA SRS Crossover Wiring Diagram
25. SDA SRS 1.2
26. SDA SRS 1.2TL
27. SDA SRS 1.2TL Right Channel Wiring Diagram
28. SDA SRS 1.2TL Left Channel Wiring Diagram

S.D.A. - CRS CROSSOVER

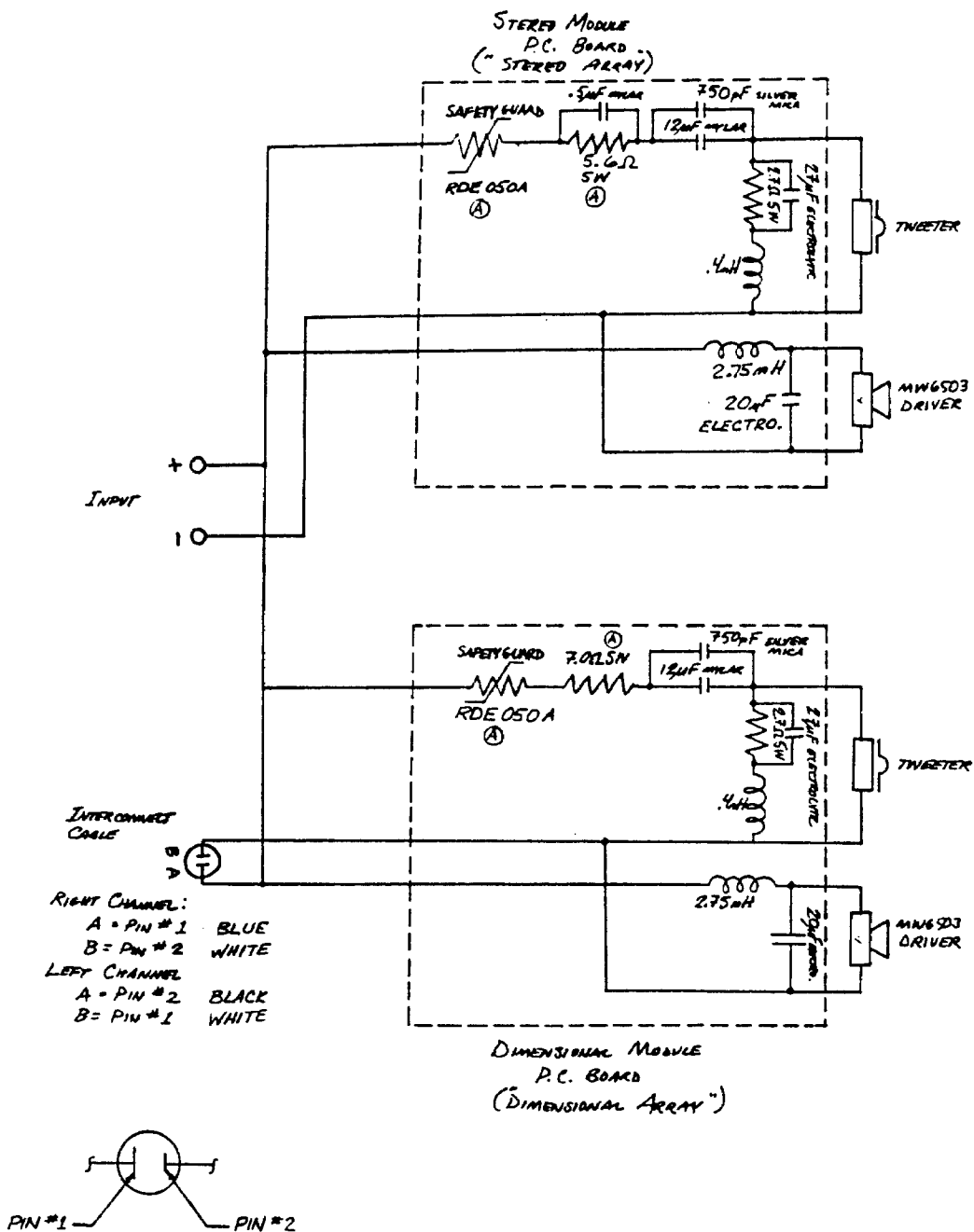

polkaudio		DATE	11/28/84	PART DESCRIPTION	S.D.A. - CRS CROSSOVER	PART NUMBER	N/A	SCALE	N/A	DATE	SYM	REVISION RECORD	DR	CL
		TOLERANCES (EXCEPT AS NOTED)	DECIMAL	FRACTIONAL	ANGULAR	DRAWN BY	J. W. HEDDINGER	DRAWING NUMBER	PO133001	APPROVED BY			5.6Ω WAS 6.2Ω; DELETED FUSES; ADDED RDE050A; 7.0Ω WAS 7.5Ω.	43

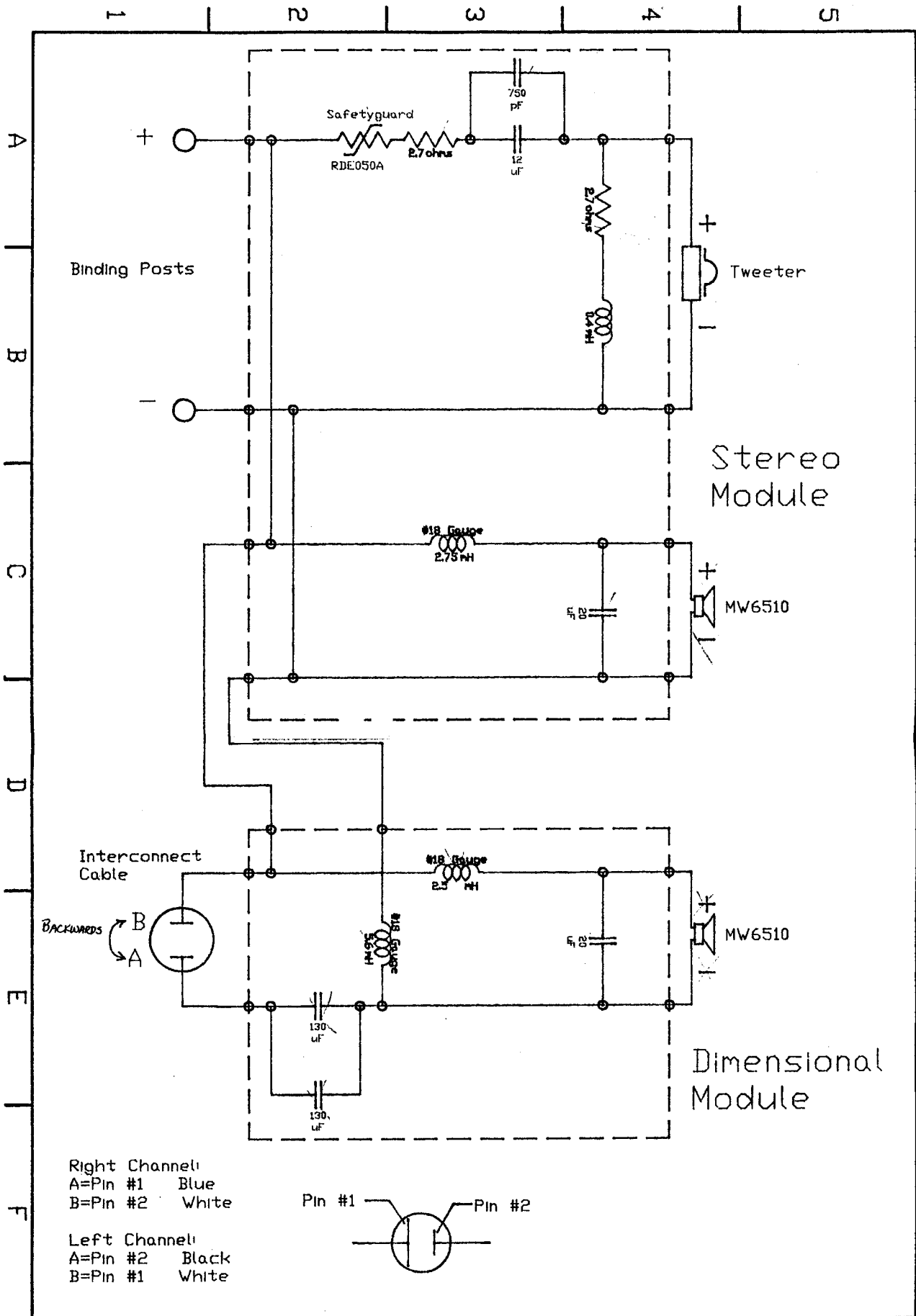

polkaudio			DATE 6/20/86	PART DESCRIPTION SDA CRS+ Schematic				
TOLERANCES EXCEPT AS NOTED	DECIMAL	FRACTIONAL	ANGULAR					
DRAWING NUMBER P0132002	SCALE		DRAWN BY Glutfelty	DATE	SYN	REVISION RECORD		DR CK
			APPROVED BY <i>[Signature]</i>	USED IN:				

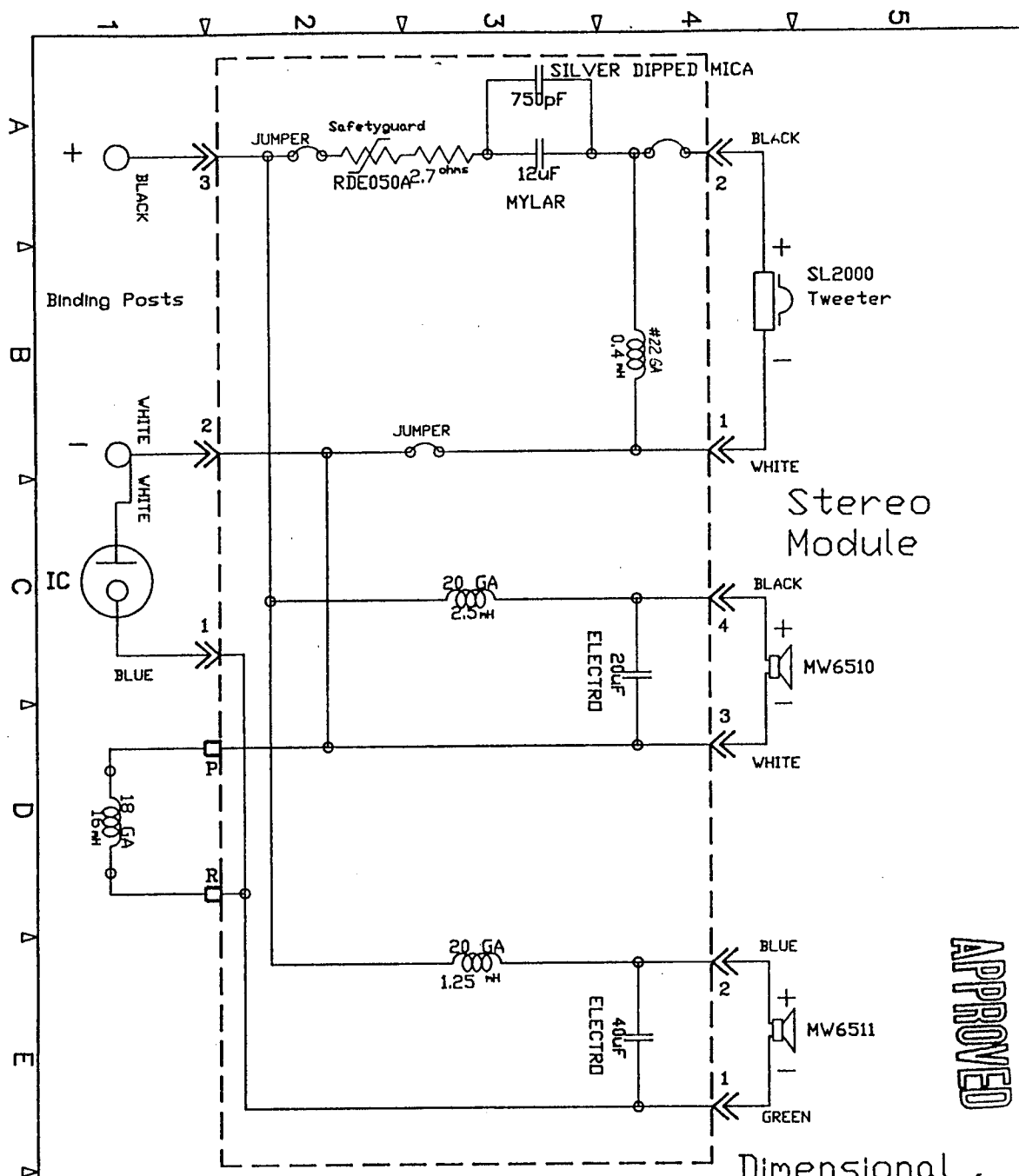

THE IC WIRE FROM THE CROSSOVER SHOULD ALWAYS BE CONNECTED TO PIN#2 (THE ROUND PIND.)

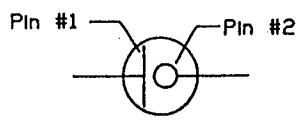

APPROVED

JUL 28 1989

PART DESCRIPTION: SCHEMATIC, SDA CRS+ NC		DECIMAL: 2 PLG 3 PLG		
DRAWING TYPE: PRODUCT		DRAWING NUMBER: P0133002	*N/A	*N/A
DRAWN BY: J.B.POLING		PART NUMBER: N/A	*N/A	
DATE: 7/26/89	VIEW NUMBER: 1	QA APPROVAL: <i>[Signature]</i>	DATE: 8-1-89	ANGULAR: *N/A
ENGINEERING APPROVAL: <i>[Signature]</i>		DATE: 8-1-89	*N/A	
REVISION RECORD			DR	CX

S.D.A. - II CROSSOVER

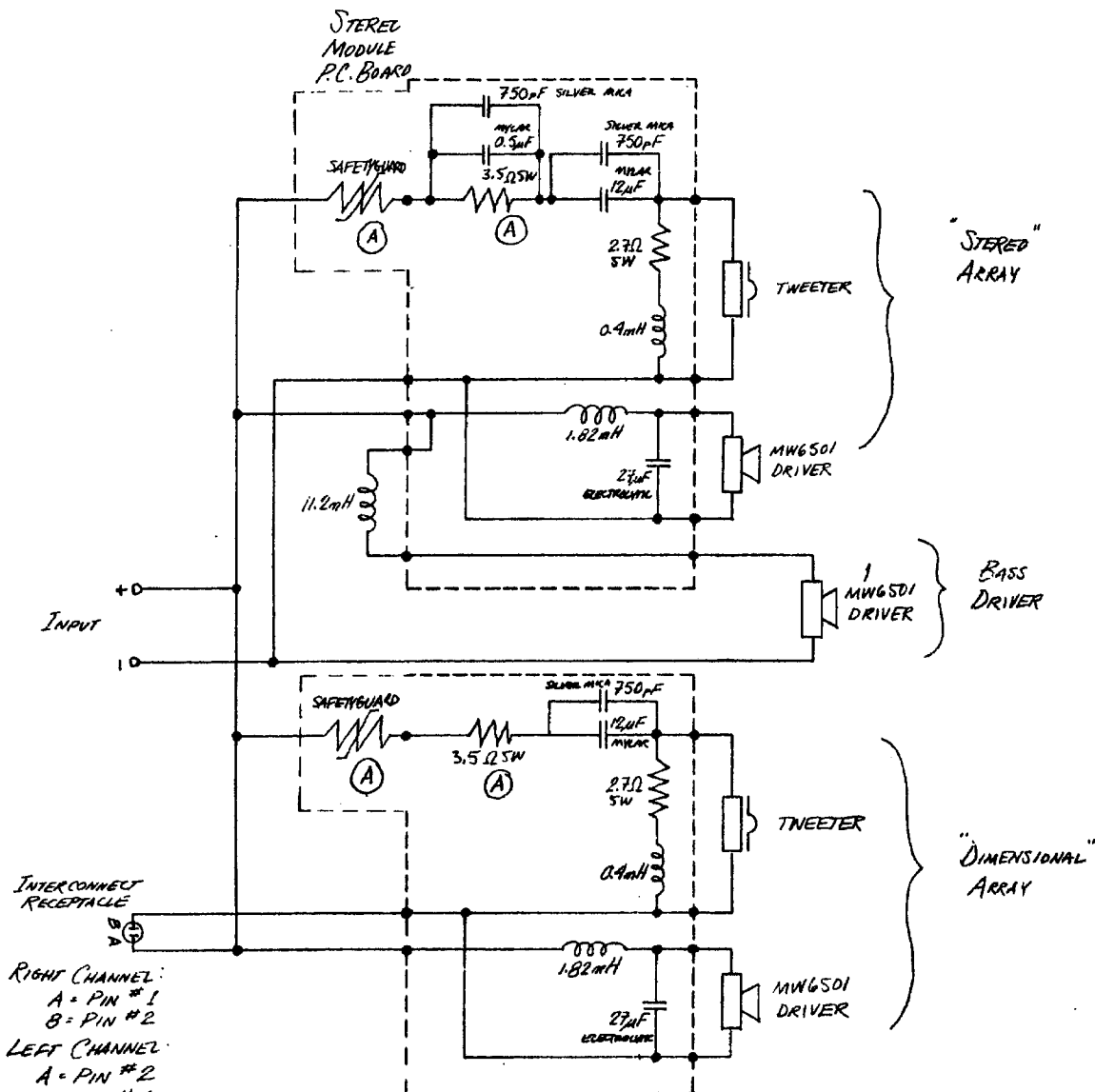

RIGHT CHANNEL:
A = PIN #1
B = PIN #2

LEFT CHANNEL:
A = PIN #2
B = PIN #1



PLEASE NOTE
↓

polkaudio	DATE	11/26/84	PART DESCRIPTION	S.D.A. - II CROSSOVER	PART NUMBER	N/A	SCALE	N/A	DATE	SYM	7/1 (A)	REVISION RECORD	DR	CK
	TOLERANCES (EXCEPT AS NOTED)	DECIMAL	FRACTIONAL	ANGULAR	DRAWN BY	J.W. HEIDINGER	DRAWING NUMBER					FUSE: ADD POLY SWITCH		
				APPROVED BY	(Signature)							# RDE030A		

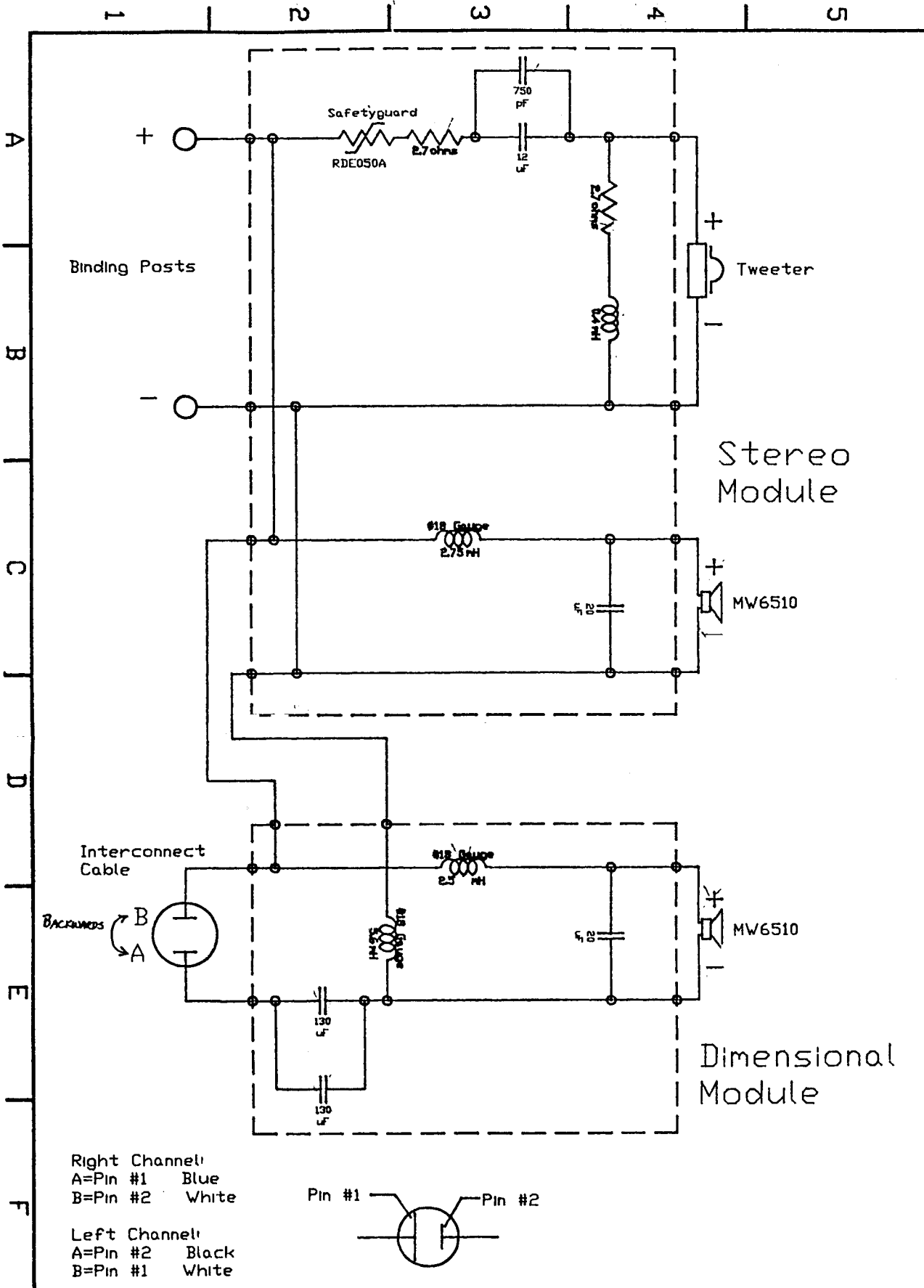

Pro Sound

DATE
6/20/86

PART DESCRIPTION
SDA 2A
Schematic

TOLERANCES
UNLESS AS NOTED

SCALE

DRAWN BY
Glotfelty

DATE SYN

REVISION RECORD

DR CK

DRAWING NUMBER
P0132002

SCALE

APPROVED BY
[Signature]

USED EN

REVISION RECORD

DR CK

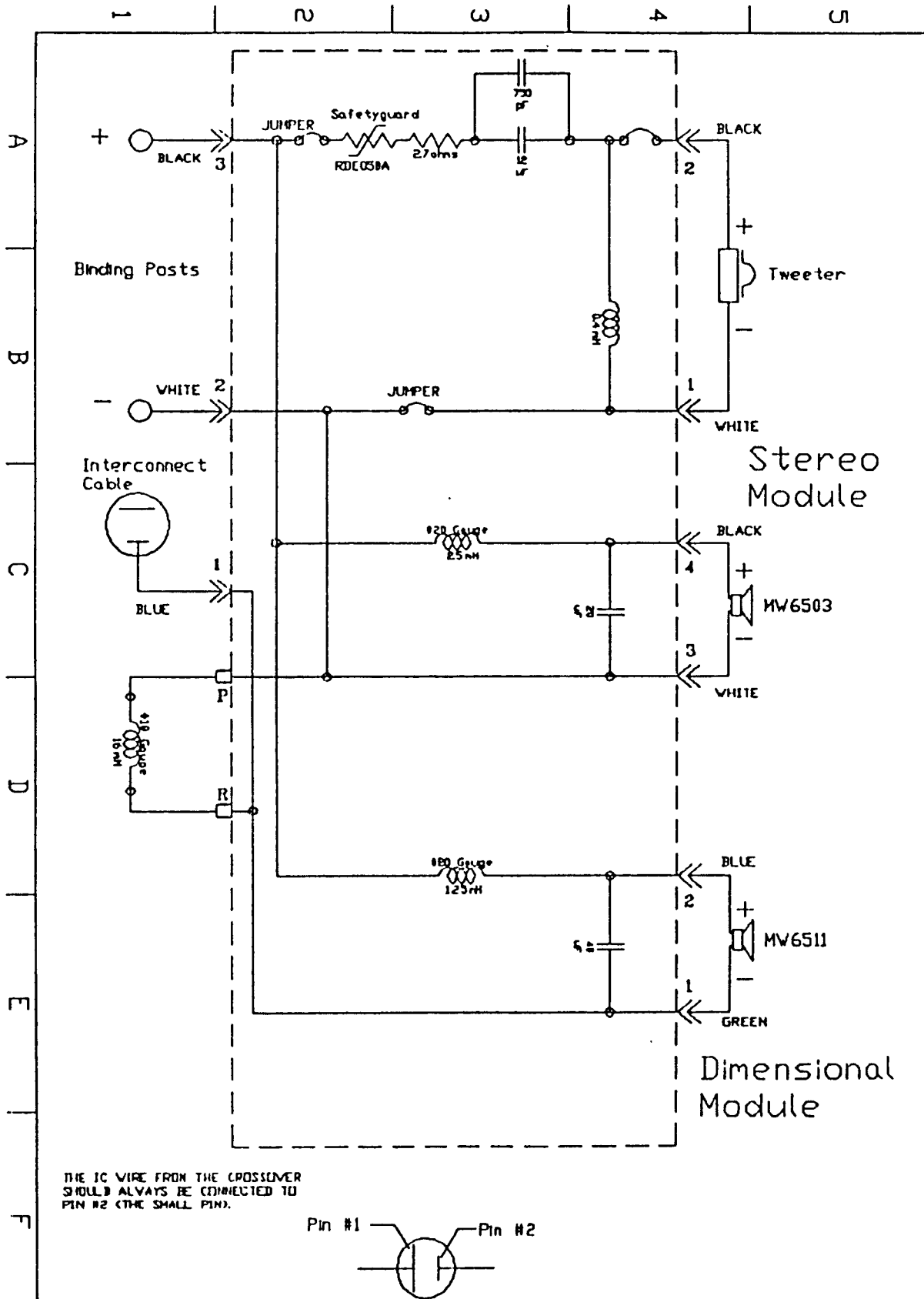

pollaudio			DATE 03/30/87	PART DESCRIPTION SDA 2B SCHEMATIC DC					
DESIGNED CHECKED AS NOTED	DESIGN	FUNCTIONAL	APPROVAL						
DRAWING NUMBER P0132002			SCALE	DRAWN BY Glofelty	DATE	SYM	REVISION RECORD	DR	CK
				APPROVED BY <i>[Signature]</i>	REV BY A17XX-CX				

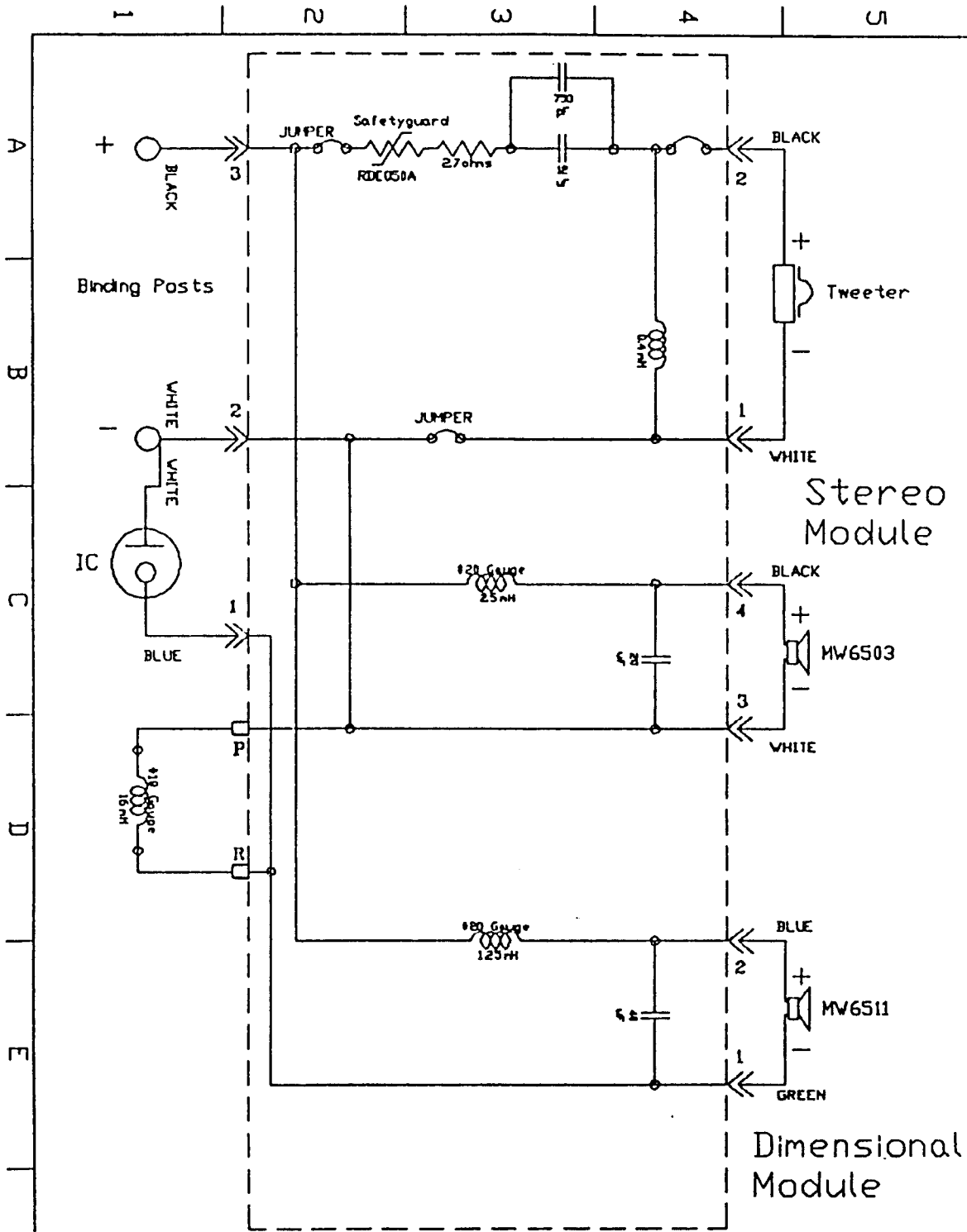

THE IC WIRE FROM THE CROSSOVER SHOULD ALWAYS BE CONNECTED TO PIN#2 (THE ROUND PIN)

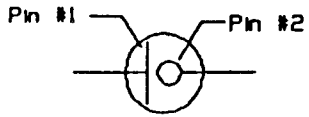

Polk Audio			DATE	PART DESCRIPTION					
			10/26/87	SDA 2B/CRS+ SCHEMATIC NC					
TOLERANCE	RESUME	FRACTIONAL	SCALE	DRAWN BY		DATE	SYM	REVISION RECORD	DR CK
±	-	±	-	GLOTFELTY					
PROVIDE NUMBER			SCALE	APPROVED BY		LED BY			
P0132003			-	<i>[Signature]</i>		A17XX-DX, A18XX-DX			

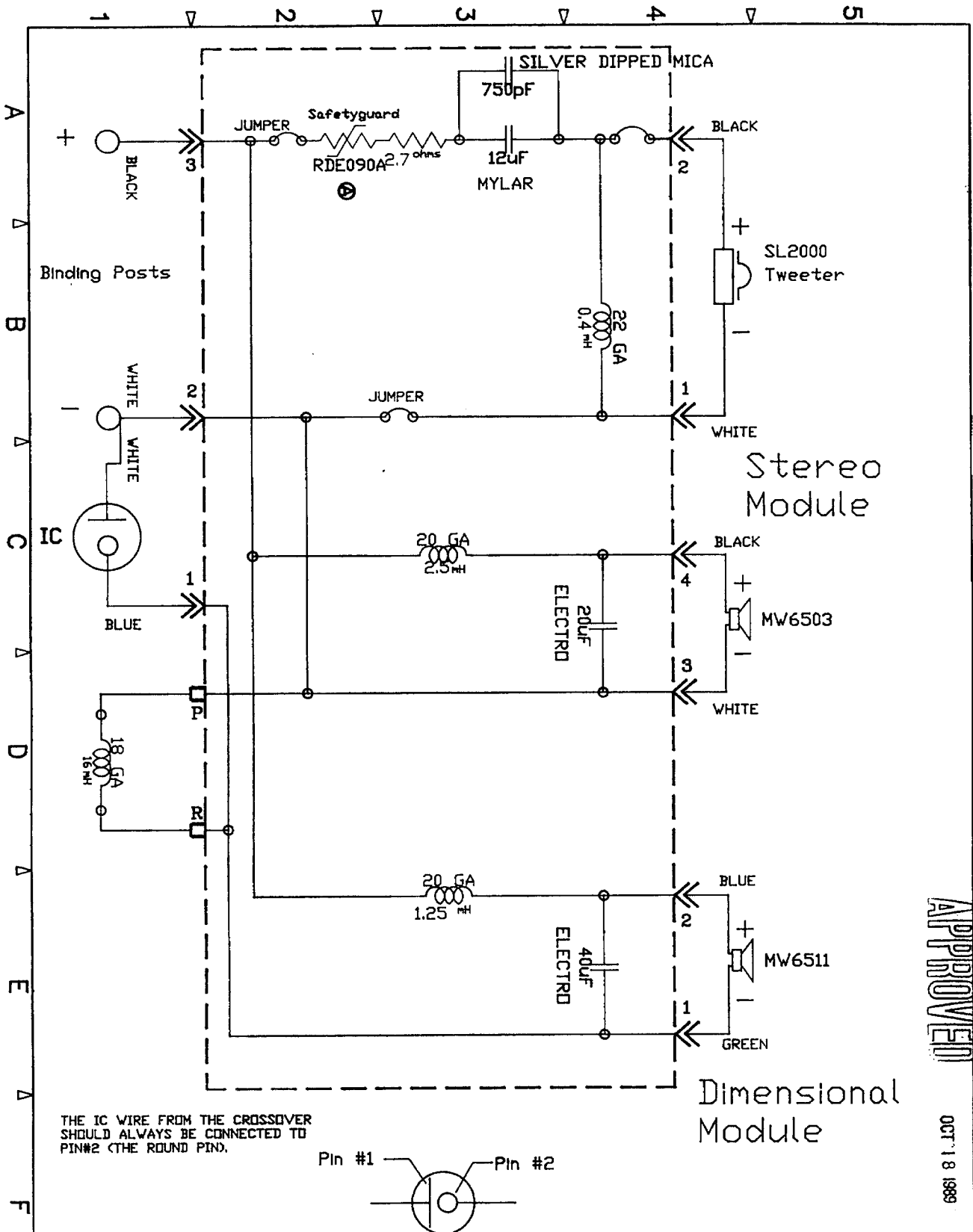

APPROVED

OCT 18 1989

PART DESCRIPTION: SCHEMATIC, SDA 2B NC		DECIMAL: 2 PLC 3 PLC			
DRAWING TYPE: PRODUCT		DRAWING NUMBER: P0132003		±N/A	±N/A
DRAWN BY: J.B.POLING		PART NUMBER: BE1807-B		FRACTIONAL:	
DATE: 7/26/89	VIEW NUMBER: 1	Q.A. APPROVAL: <i>[Signature]</i>		DATE: 10/13/89	
pollaudio		ENGINEERING APPROVAL: <i>[Signature]</i>		DATE: 10-12-89	
		O.A. APPROVAL: <i>[Signature]</i>		DATE: 10-12-89	
		ANGULAR: ±N/A		±N/A	
		ANGULAR: ±N/A		±N/A	
		DATE SYM:		REVISION RECORD	
		WHERE USED: AS1700-PL DR		DR CK	
		9/89 RDE090 WAS RDE050		RJS	

SDA 2B RIGHT CHANNEL

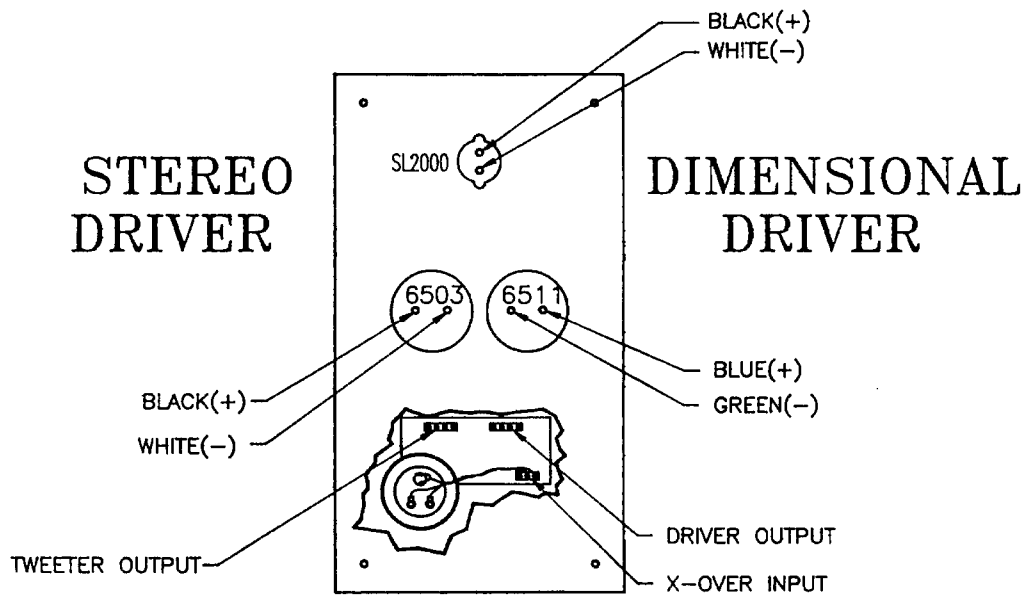

APPROVED

OCT 19 1989

PART DESCRIPTION: SDA 2B WIRING DIAGRAM (RC)		DECIMAL: 2 PLC 3 PLC			
DRAWING TYPE: PROCESS	DRAWING NUMBER: M9101040	±.02 ±.015			
DRAWN BY: RICK SCHIMPF II	PART NUMBER: NA	FRACTIONAL: ±1/32			
DATE: 10/3/89	VIEW NUMBER: 1 OF 2	ANGULAR: ±0°30			
		DATE SYM	REVISION RECORD	DR	CK
Q.A. APPROVAL: <i>[Signature]</i> DATE: 10/12/89 ENGINEERING APPROVAL: <i>[Signature]</i> DATE: 10/12/89		WHERE USED: N/A			

SDA 2B LEFT CHANNEL

A
B
C
D
E
F

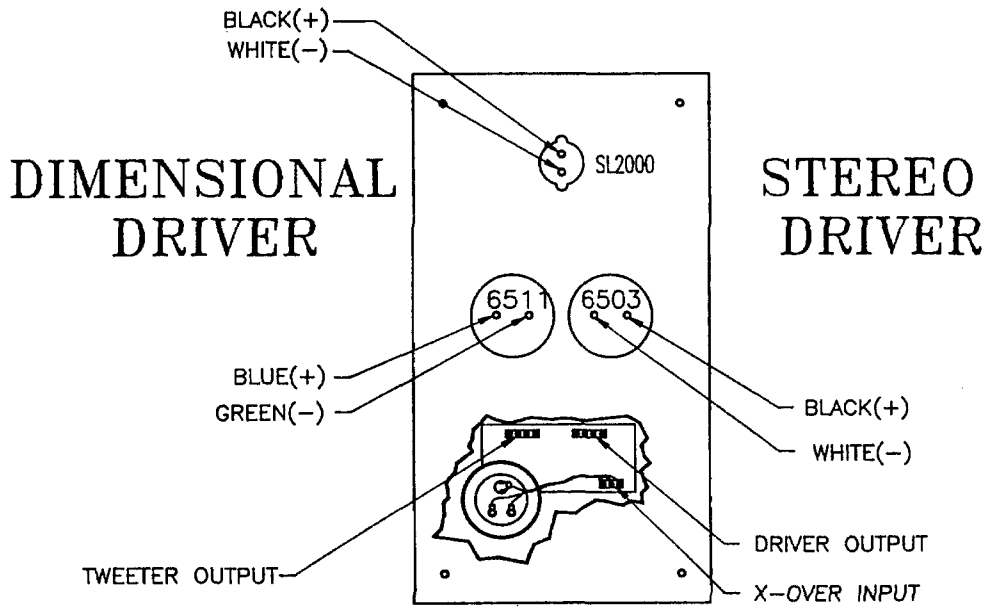

APPROVED

OCT 19 1989

PART DESCRIPTION: SDA 2B WIRING DIAGRAM (LC)		DECIMAL: 2 PLC 3 PLC					
DRAWING TYPE: PROCESS		DRAWING NUMBER: M9101040		±.02	±.015		
DRAWN BY: RICK SCHIMPF II		PART NUMBER: NA		FRACTIONAL: ±1/32			
DATE: 10/3/89	VIEW NUMBER: 20F2	DATE APPROVAL: <i>[Signature]</i>	DATE: 10/17/89	ANGULAR: ±0°30	DATE SYM		REVISION RECORD
pollkaudio		ENGINEERING APPROVAL: <i>[Signature]</i>		DATE: 10/12/89	WHERE USED: N/A		DR CK

SDA I CROSSOVER

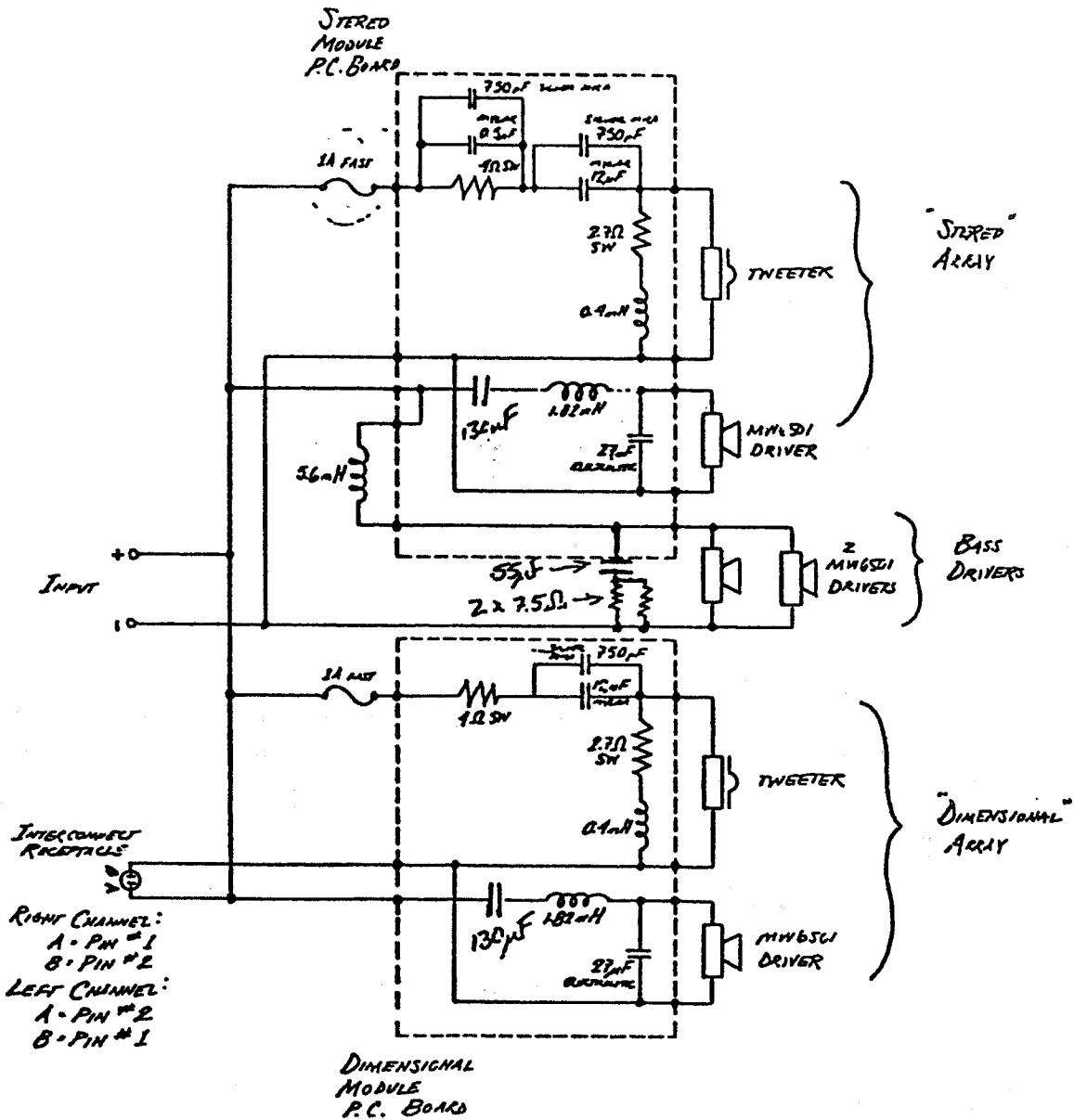

polkaudio		DATE	PART DESCRIPTION	PART NUMBER	SCALE	DATE	SYN	REVISION REQUIRED	DR	OK
			SDA-I CROSSOVER	N/A	N/A					
TOLERANCES EXCEPT AS NOTED	DECIMAL FRACTIONAL ANGULAR		DRAWN BY APPROVED BY		DRAWING NUMBER					

S.D.A. - IA CROSSOVER

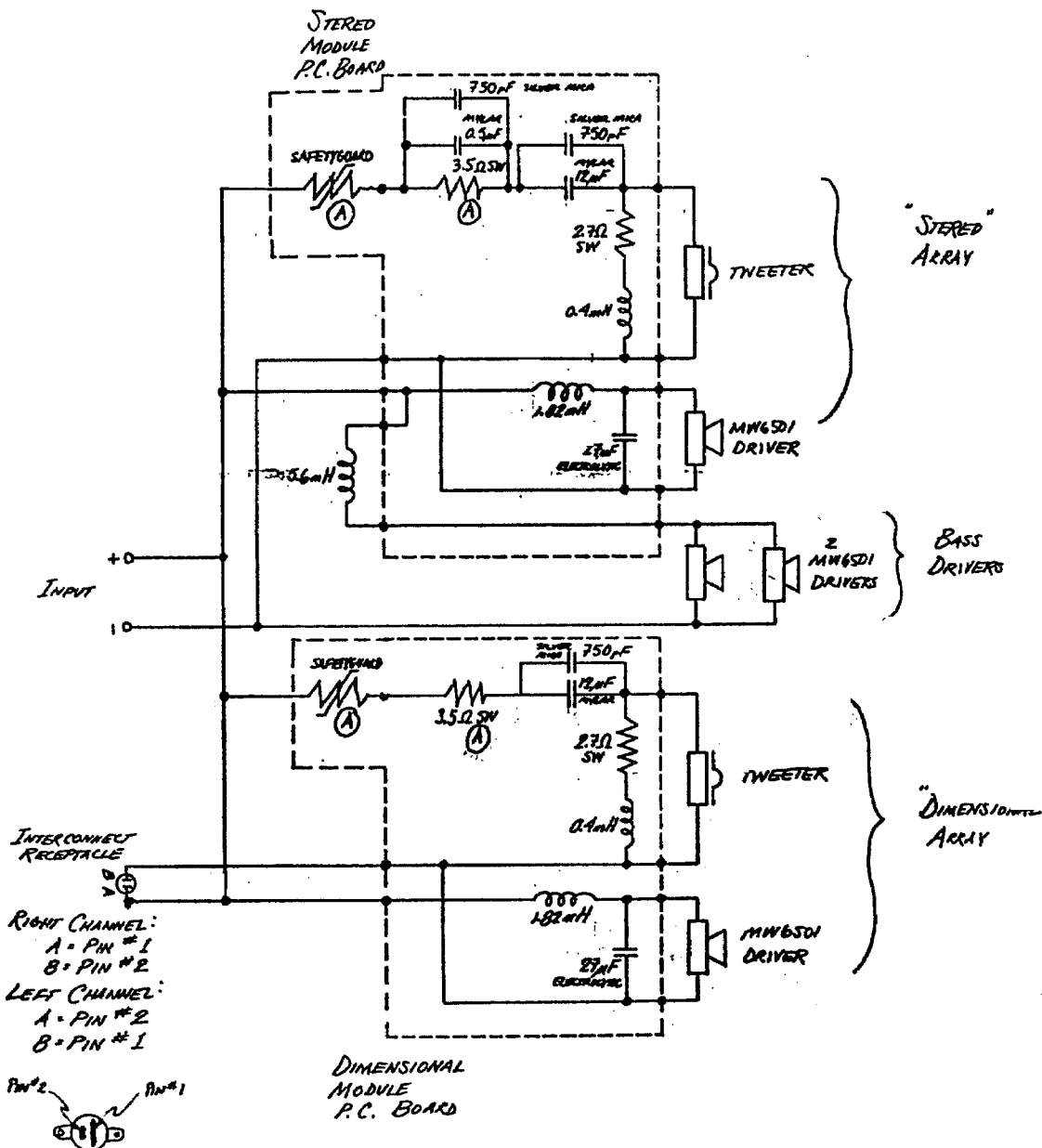

polkaudio		DATE	11/26/84	PART DESCRIPTION	S.D.A. - IA CROSSOVER	PART NUMBER	N/A	SCALE	N/A	DATE	SYM	REVISION RECORD	DR.	CK.
TOLERANCES (EXCEPT AS NOTED)		DECIMAL	FRACTIONAL	ANGULAR	DRAWN BY J.W. HERMINGER		DRAWING NUMBER		POB31001		3.5Ω WAS 4Ω; DELETED			
					APPROVED BY						PIES; ADDED POLYSPHERES			
											# RDE 05DA			

1 2 3 4 5

A
B
C
D
E
F

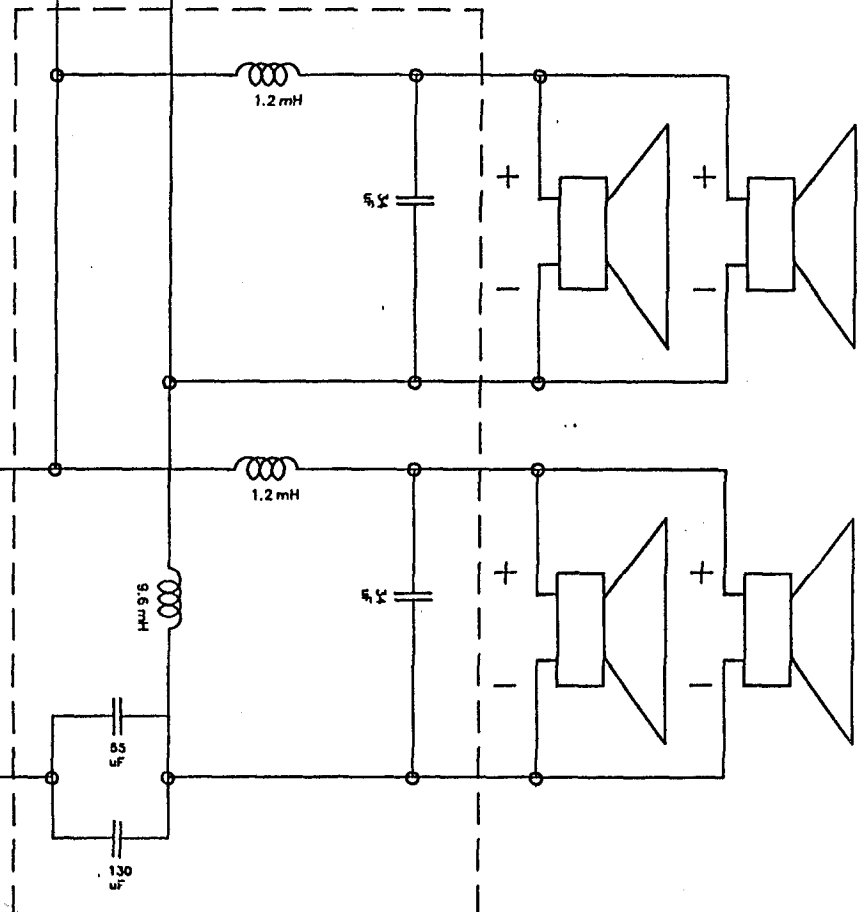
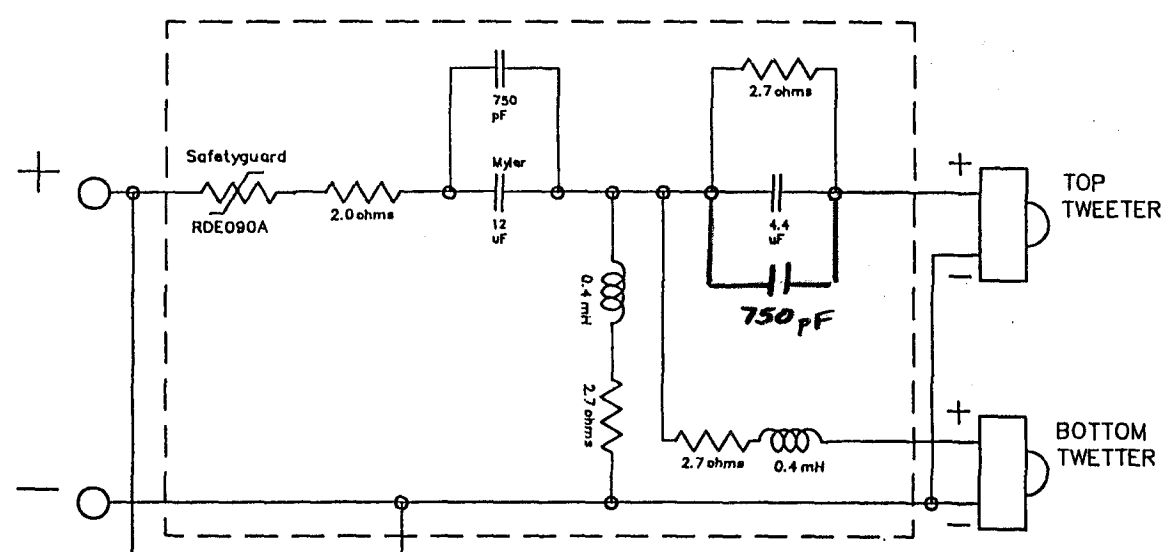

Right Channel:
A=Pin #1 Blue
B=Pin #2 White

Left Channel:
A=Pin #2 Black
B=Pin #1 White

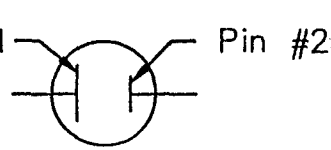

pollkaudio			DATE 11/20/86	PART DESCRIPTION SDA-1B SCHEMATIC							
TOLERANCES (EXCEPT AS NOTED)			DECIMAL	FRACTIONAL	ANGULAR						
DRAWING NUMBER P0131002			SCALE	DRAWN BY Glotfelty	DATE	SYM	REVISION RECORD		DR	CK	
				APPROVED BY <i>Just</i>	USED ON: SDA-1B						

VP

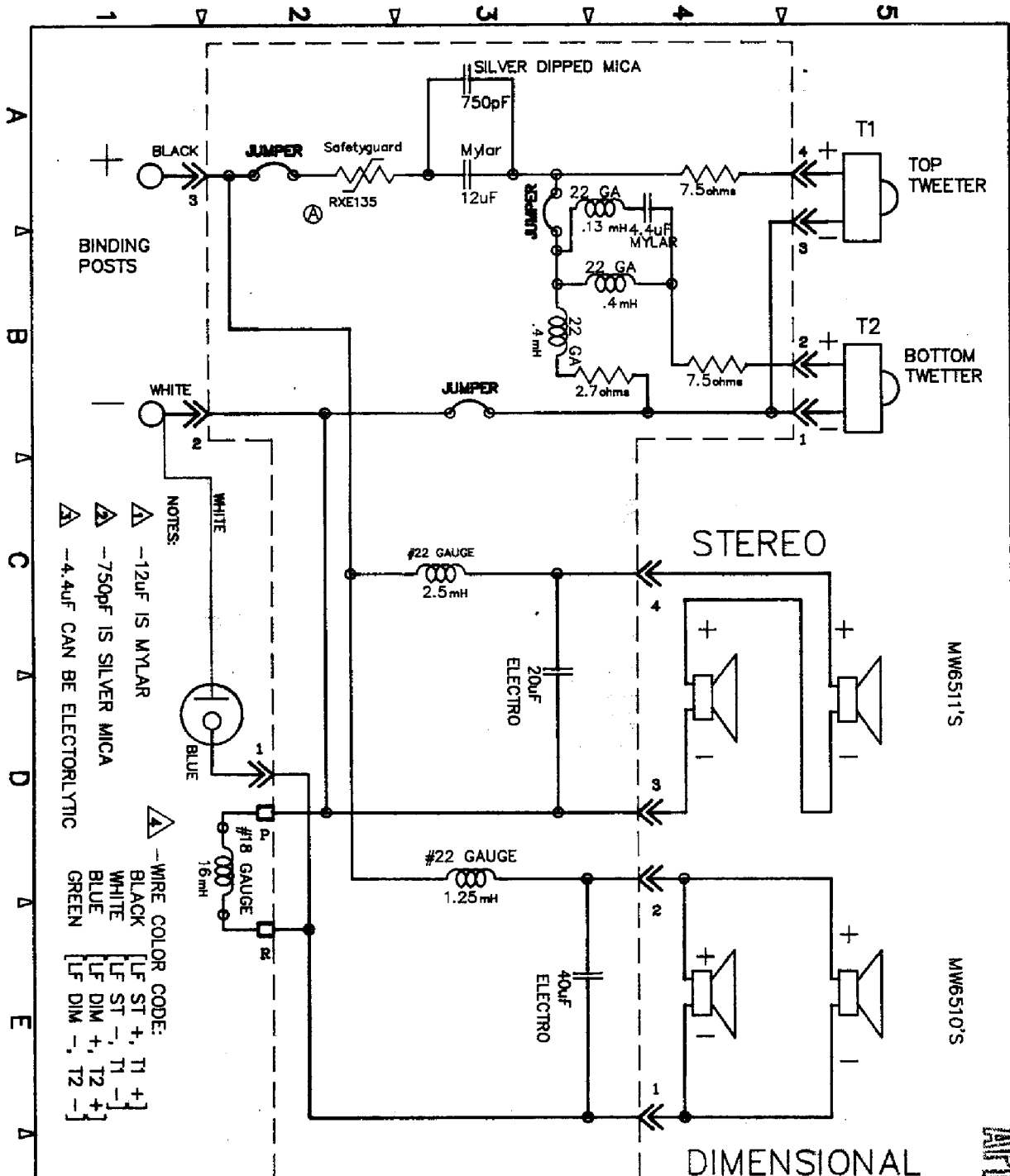

- NOTES:
- ▲ -12uF IS MYLAR
 - ▲ -750pF IS SILVER MICA
 - ▲ -4.4uF CAN BE ELECTROLYTIC

- WIRE COLOR CODE:
- BLACK [LF ST +, T1 +]
 - WHITE [LF ST -, T1 -]
 - BLUE [LF DIM +, T2 +]
 - GREEN [LF DIM -, T2 -]

THE IC WIRE FROM THE CROSSOVER SHOULD ALWAYS BE CONNECTED TO PIN #2 (THE ROUND PIN).

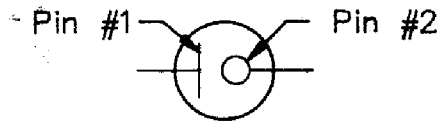

APPROVED

REV 3 1988

PART DESCRIPTION: SCHEMATIC, SDA 1C NC		DECIMAL: 2 PLG 1 3 PLG			
DRAWING TYPE: PRODUCT	DRAWING NUMBER: P0131003	2N/A 3N/A			
DRAWN BY: J.B.POLING	PART NUMBER: BE1618-B	FRACTIONAL: 2N/A			
DATE: 7/26/89	NEW NUMBER:	DATE: 10/30/89	9/89 (A) RXE135 WAS RDE070		RJS
ENGINEER'S APPROVAL: <i>[Signature]</i>		DATE: 10-27-89	DATE SYN:	REVISION RECORD	DR CK
WHERE USED: AS1618-01/DR					

SDA 1C LEFT CHANNEL

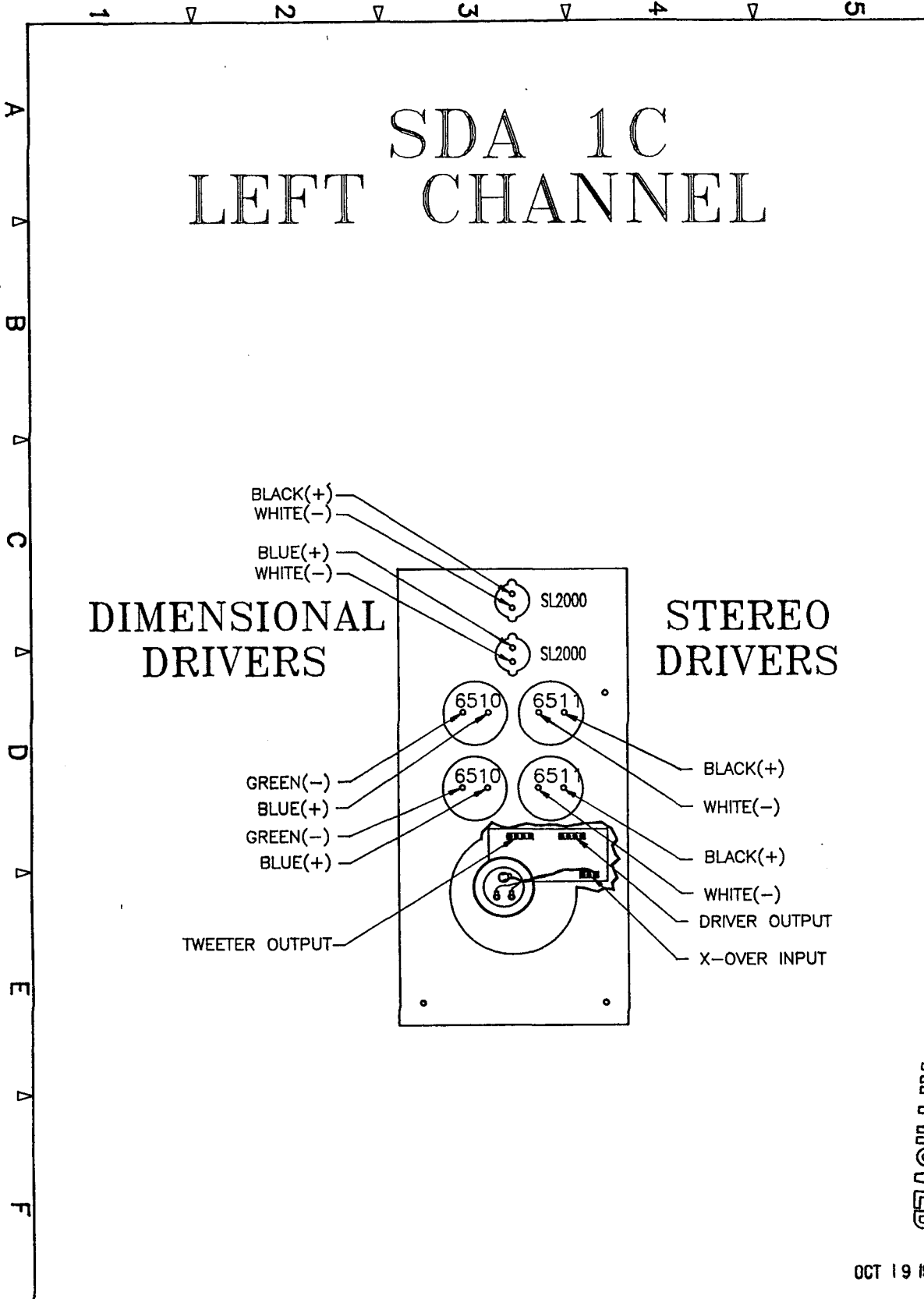

APPROVED

OCT 19 1989

PART DESCRIPTION: SDA 1C WIRING DIAGRAM (LC)		DECIMAL: 2 PLC 3 PLC					
DRAWING TYPE: PROCESS		DRAWING NUMBER: M9101038		±.02	±.015		
DRAWN BY: RICK SCHIMPF II		PART NUMBER: NA		FRACTIONAL: ±1/32			
DATE: 10/3/89	VIEW NUMBER: 1 of 2	DATE: 10/10/89	DATE: 10/12/89	ANGULAR: ±0°30		DATE SYM	REVISION RECORD
polls audio		ENGINEERING APPROVAL:		WHERE USED: N/A		DR	CK

SDA 1C RIGHT CHANNEL

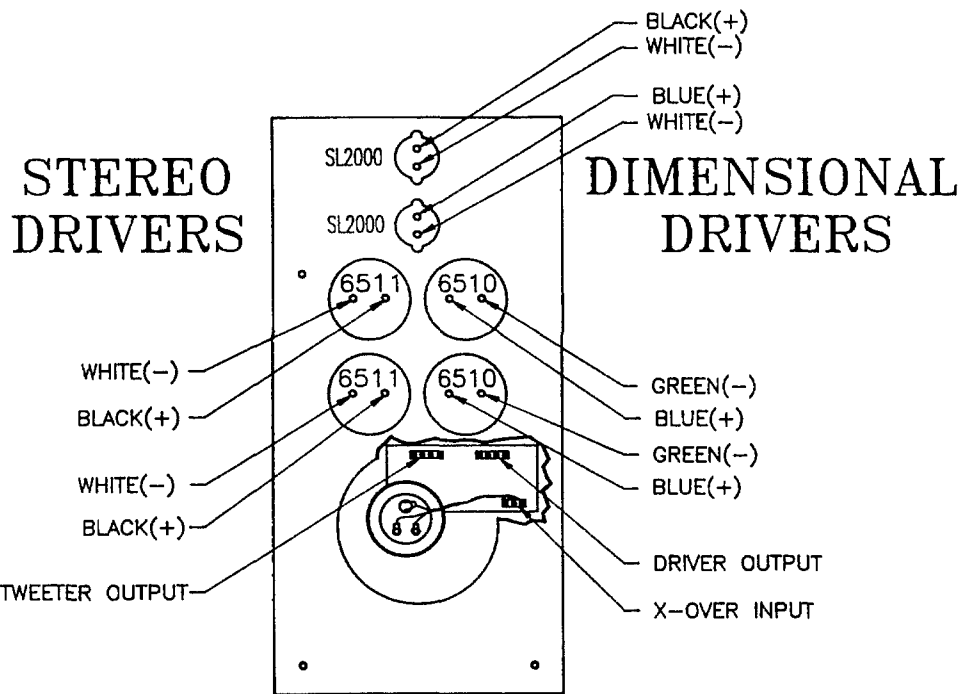

APPROVED

OCT 19 1989

PART DESCRIPTION: SDA 1C WIRING DIAGRAM (RC)		DECIMAL: 2 PLC 3 PLC			
DRAWING TYPE: PROCESS		DRAWING NUMBER: M9101038		±.02	±.015
DRAWN BY: RICK SCHIMPF II		PART NUMBER: NA		FRACTIONAL: ±1/32	
DATE: 10/3/89	VIEW NUMBER: 2 of 2	Q.A. APPROVAL: <i>[Signature]</i>	DATE: 10/12/89	ANGULAR: ±0°30	
pollsaudio		ENGINEERING APPROVAL: <i>[Signature]</i>		DATE: 10/12/89	DATE SYM WHERE USED: N/A
				REVISION RECORD	
				DR	CK

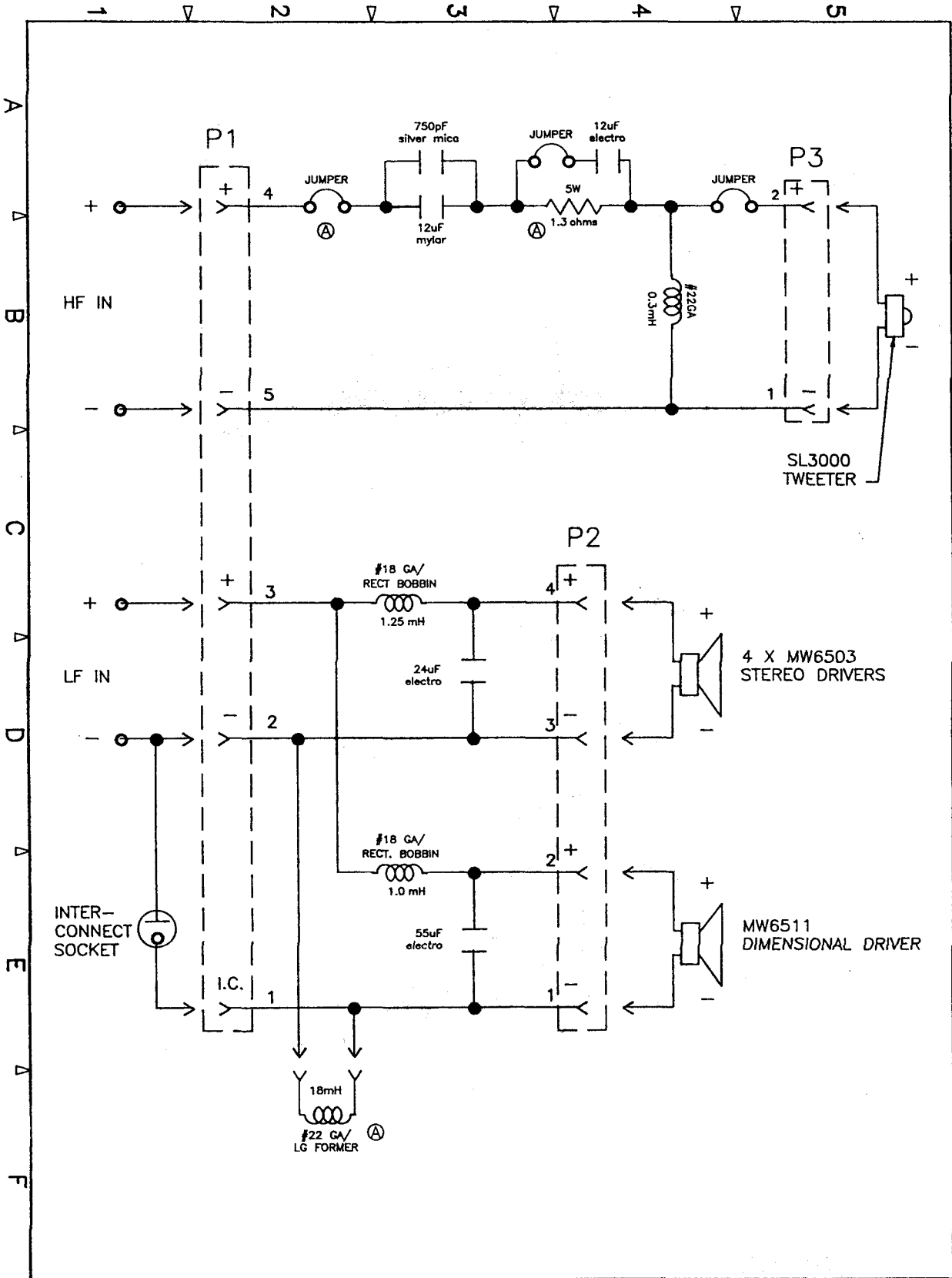

PART DESCRIPTION: SCHEMATIC, SRS 3.1tl		DECIMAL: 2 PLC 3 PLC			
DRAWING TYPE: PRODUCT	DRAWING NUMBER: P0163001	*N/A	*N/A		
DRAWN BY: MARINOS P BARIS	PART NUMBER: N/A	*N/A			
DATE: 4/12/90	VIEW NUMBER: 1 OF 1	DATE: 5/3/90	DATE SYM:	REVISION RECORD	DR CK
		ENGINEERING APPROVAL: <i>[Signature]</i> 5/3/90	DATE:	WHERE USED: AR310X-AL/AR	
		APPROVAL: <i>[Signature]</i>	DATE:	DEL POLY SWITCH: #22 GA WAS #20 GA; 1.3ohms WAS 1ohm	MPB

MAY - 3 1990
APPROVED

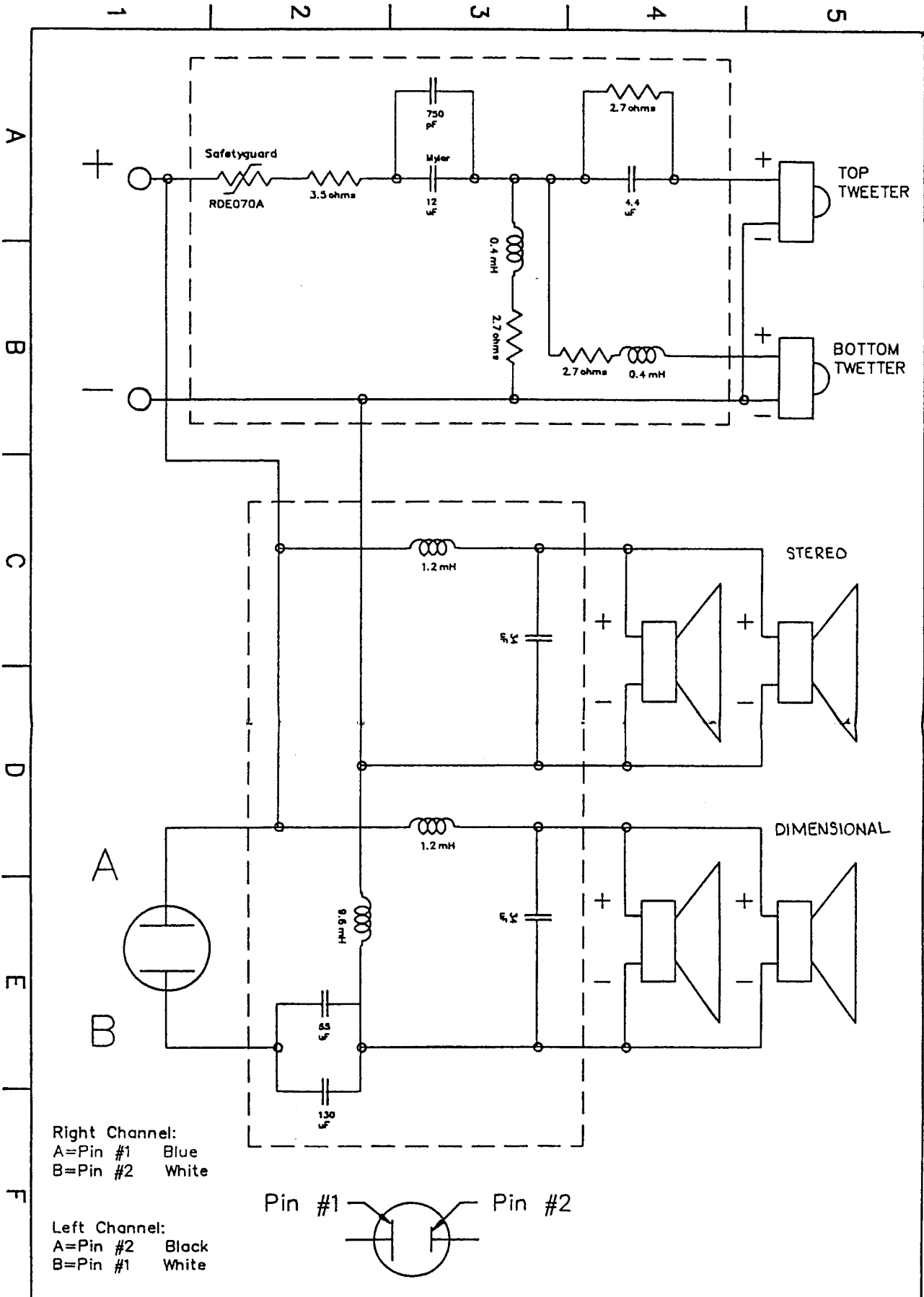

Right Channel:
 A=Pin #1 Blue
 B=Pin #2 White

Left Channel:
 A=Pin #2 Black
 B=Pin #1 White

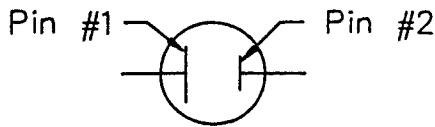

polkaudio		DATE 11/24/86	PART DESCRIPTION SRS-II SCHEMATIC				
TOLERANCES (EXCEPT AS NOTED)	DECIMAL	FRACTIONAL	ANGULAR		11/24	A	REDRAWN
DRAWING NUMBER P0162001		SCALE	DRAWN BY Glotfelty	DATE	SYM	REVISION RECORD	
			APPROVED BY <i>JMA</i>	USED ON: SRS II		OR	CK

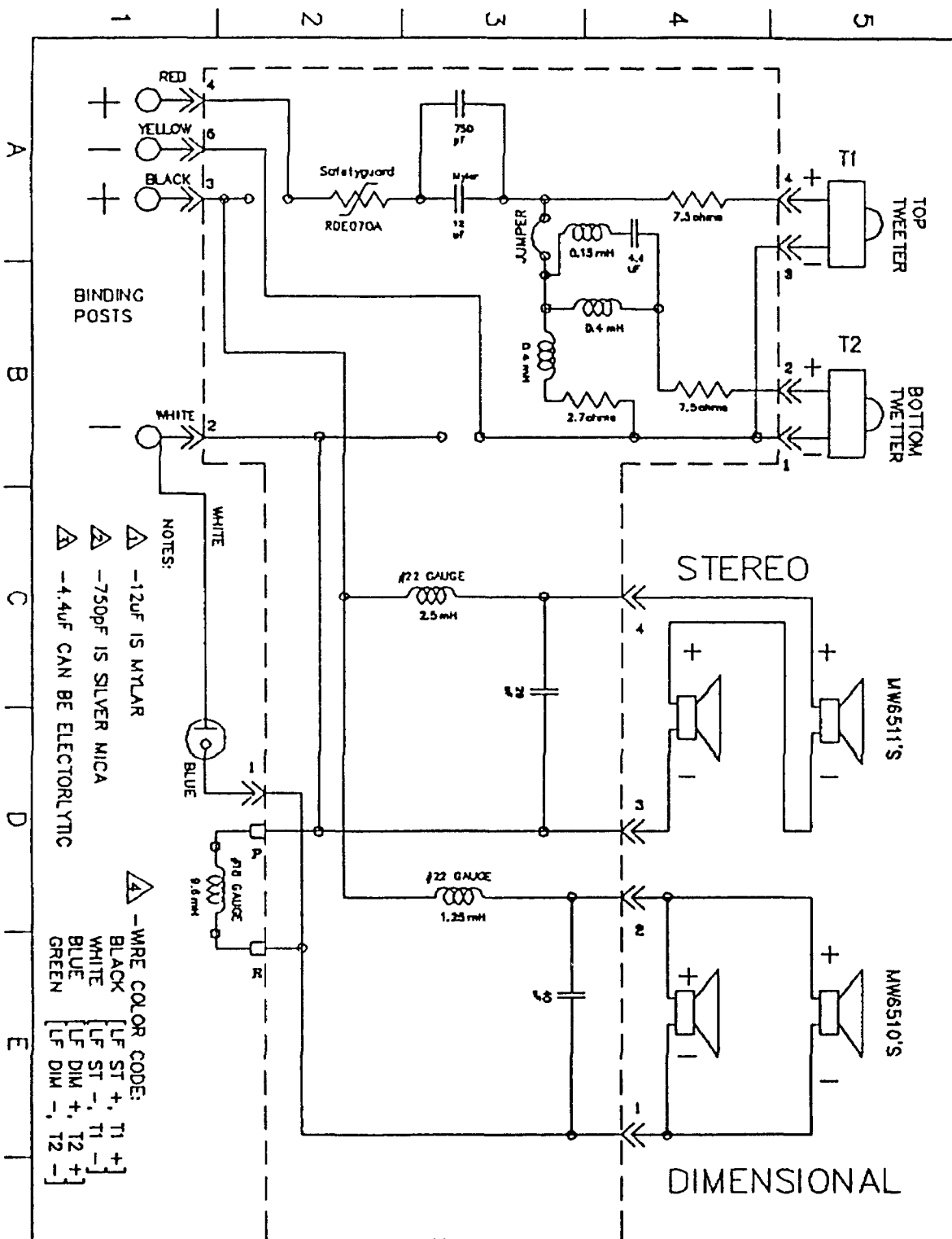

NOTES:
 Δ -12UF IS MYLAR
 Δ -750PF IS SILVER MICA
 Δ -4.4UF CAN BE ELECTROLYTIC

Δ -WIRE COLOR CODE:
 BLACK [LF ST +, T1 +]
 WHITE [LF ST -, T1 -]
 BLUE [LF DIM +, T2 +]
 GREEN [LF DIM -, T2 -]

SRS II

Polk Audio		DATE	PART DESCRIPTION					
		10/26/87	SRS II SCHEMATIC NC					
DECIMAL	FRACTIONAL	APPROX						
±	±	±						
RAW NUMBER	SCALE	DRAWN BY	DATE	SYM	REVISION RECORD		OR OK	
P0162002	-	GLOJELTY						
		APPROVED BY	JOB OR A210X-BX					

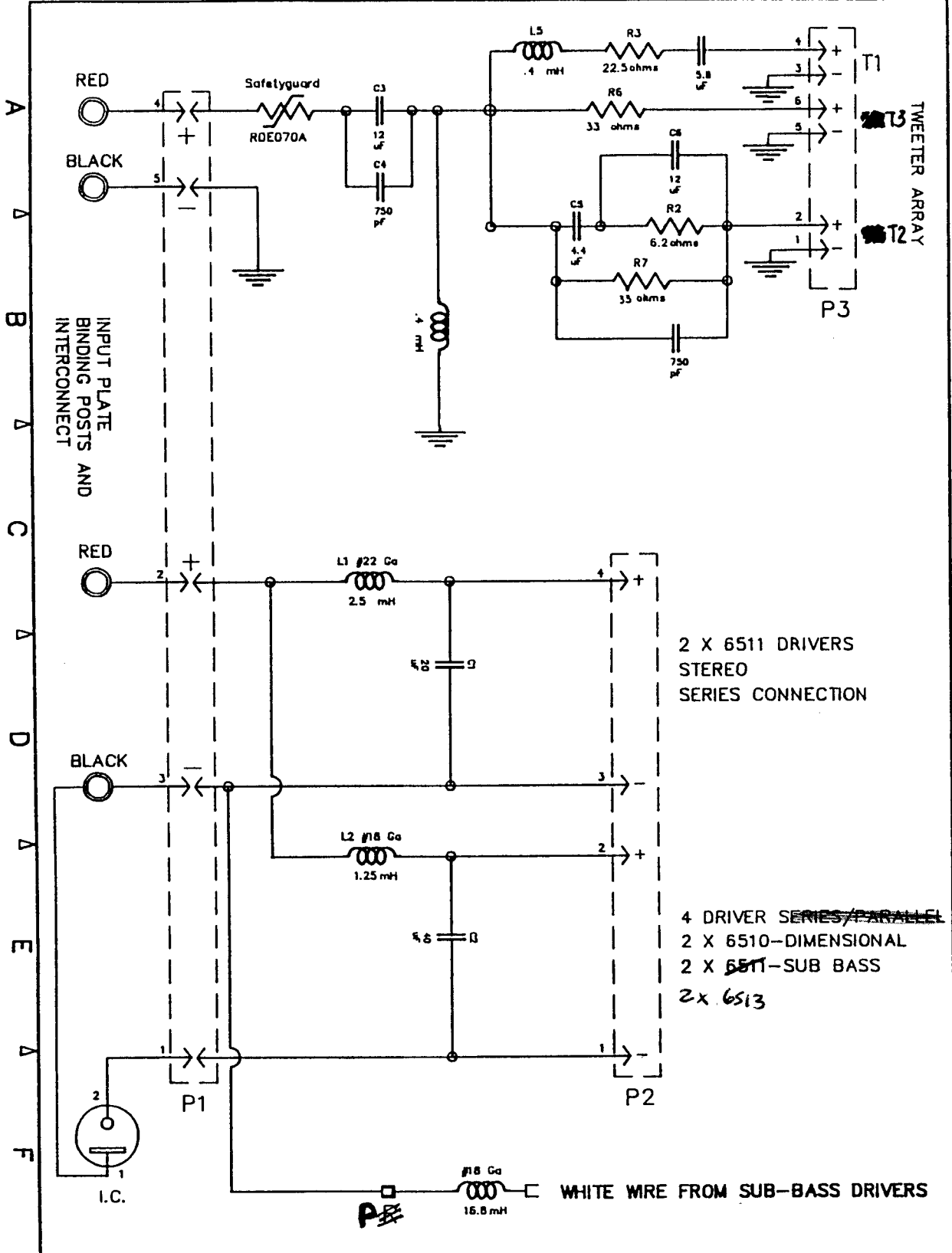

PART DESCRIPTION: SCHEMATIC, SRS 2.3		DECIMAL: 2 PLC 3 PLC					
DRAWING TYPE: PRODUCT		DRAWING NUMBER: P0162003		FRACTIONAL:			
DRAWN BY: GLOTFELTY		PART NUMBER: -		ANGULAR:			
DATE: 05/24/88	VIEW NUMBER: 1	Q.A. APPROVAL: <i>[Signature]</i>	DATE: 4/13/88	DATE SYM		REVISION RECORD	DR CK
polkaudio		FINAL APPROVAL: <i>[Signature]</i>		WHERE USED: AR200-Bx			

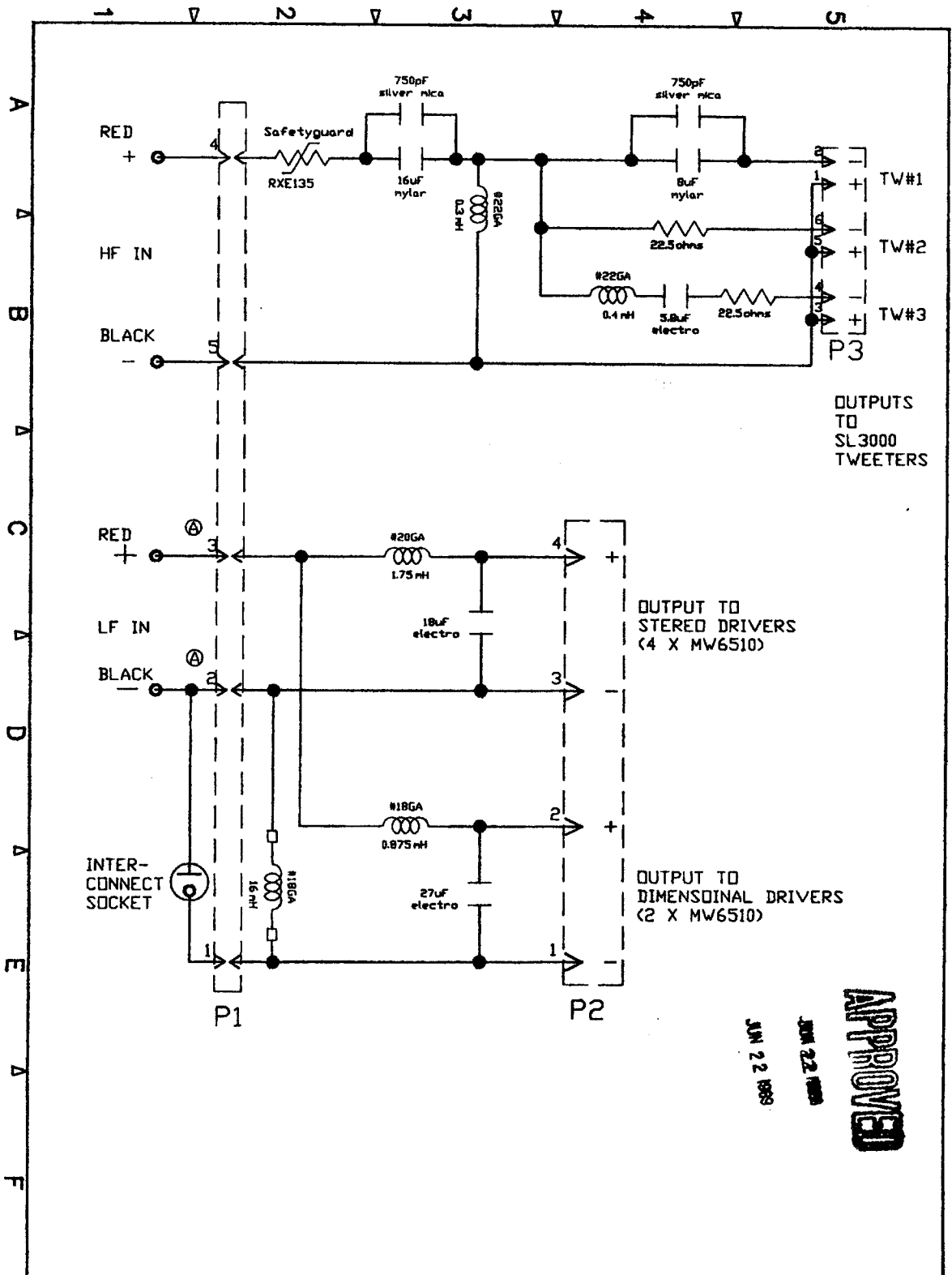

APPROVED
 JUN 22 1989
 JUN 22 1989

PART DESCRIPTION: SCHEMATIC, SRS 2.3tl		DECIMAL: 2 PLC 13 PLC			
DRAWING TYPE: PRODUCT		DRAWING NUMBER: P0162003		FRACTIONAL: N/A N/A	
DRAWN BY: J.B.POLING		PART NUMBER: N/A		5/89 (B) modified to tl series BP	
DATE: 5/31/89	VIEW NUMBER: 10F1	DATE: 6-22-89	DATE: 6-22-89	1/88 (A) pin # 2&3 reversed BP	
ENGINEERING APPROVAL: <i>[Signature]</i>		DATE: 6-22-89		DATE SYM: REVISION RECORD DR CK	
WHERE USED: AR222-B-100					

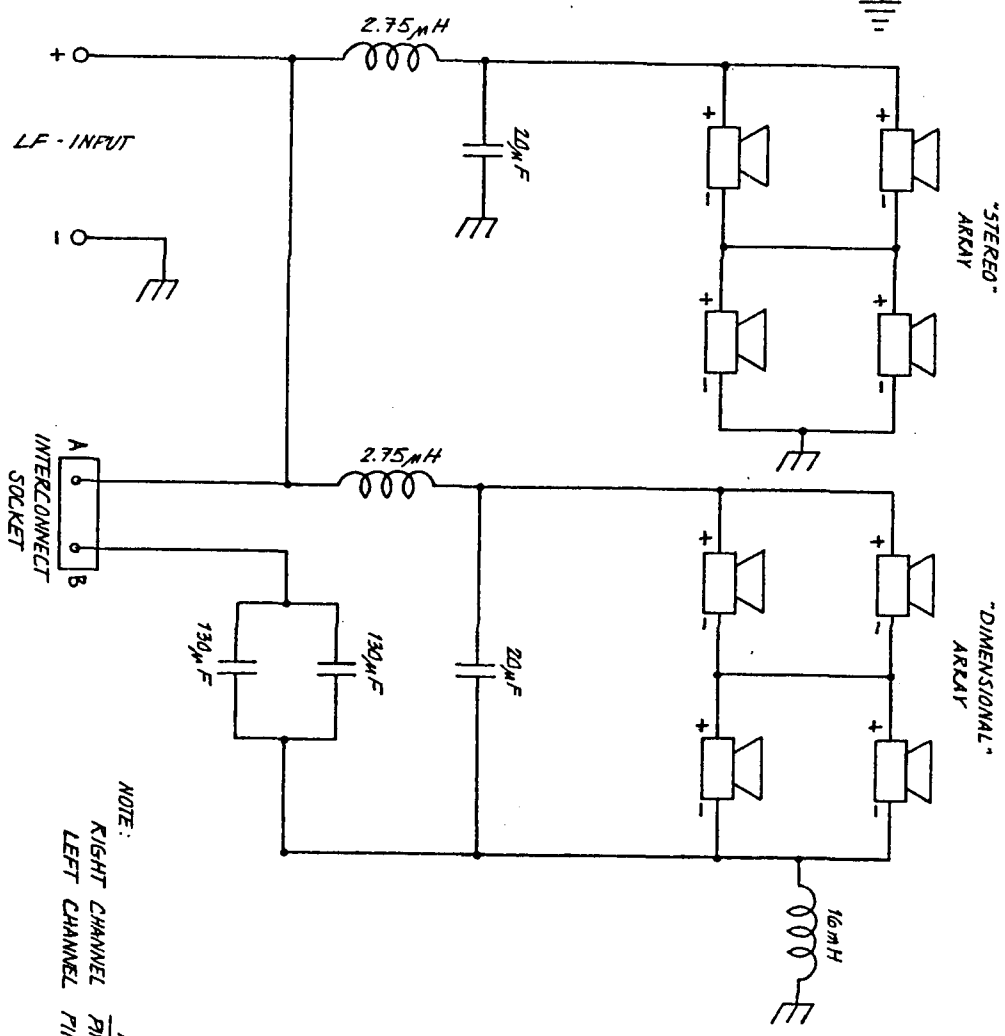
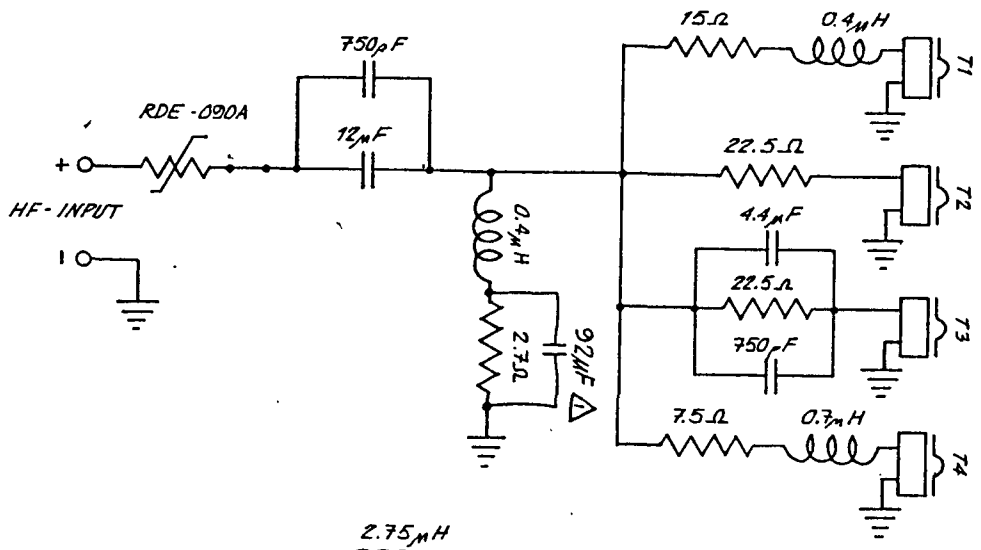

NOTE:
 RIGHT CHANNEL PIN-1 A
 LEFT CHANNEL PIN-2 B

polkaudio		DATE 8-14-85	PART DESCRIPTION SDA-SRS CROSSOVER	PART NUMBER N/A	SCALE N/A	DATE SYM 2/87 Δ	REVISION RECORD ADD 92µF CAPACITOR	DR JA	CK [Signature]
TOLERANCES (EXCEPT AS NOTED)	DECIMAL =	FRACTIONAL x	ANGULAR z	DRAWN BY J.W. HEDDINGER	DRAWING NUMBER P0161001				
				APPROVED BY [Signature]					

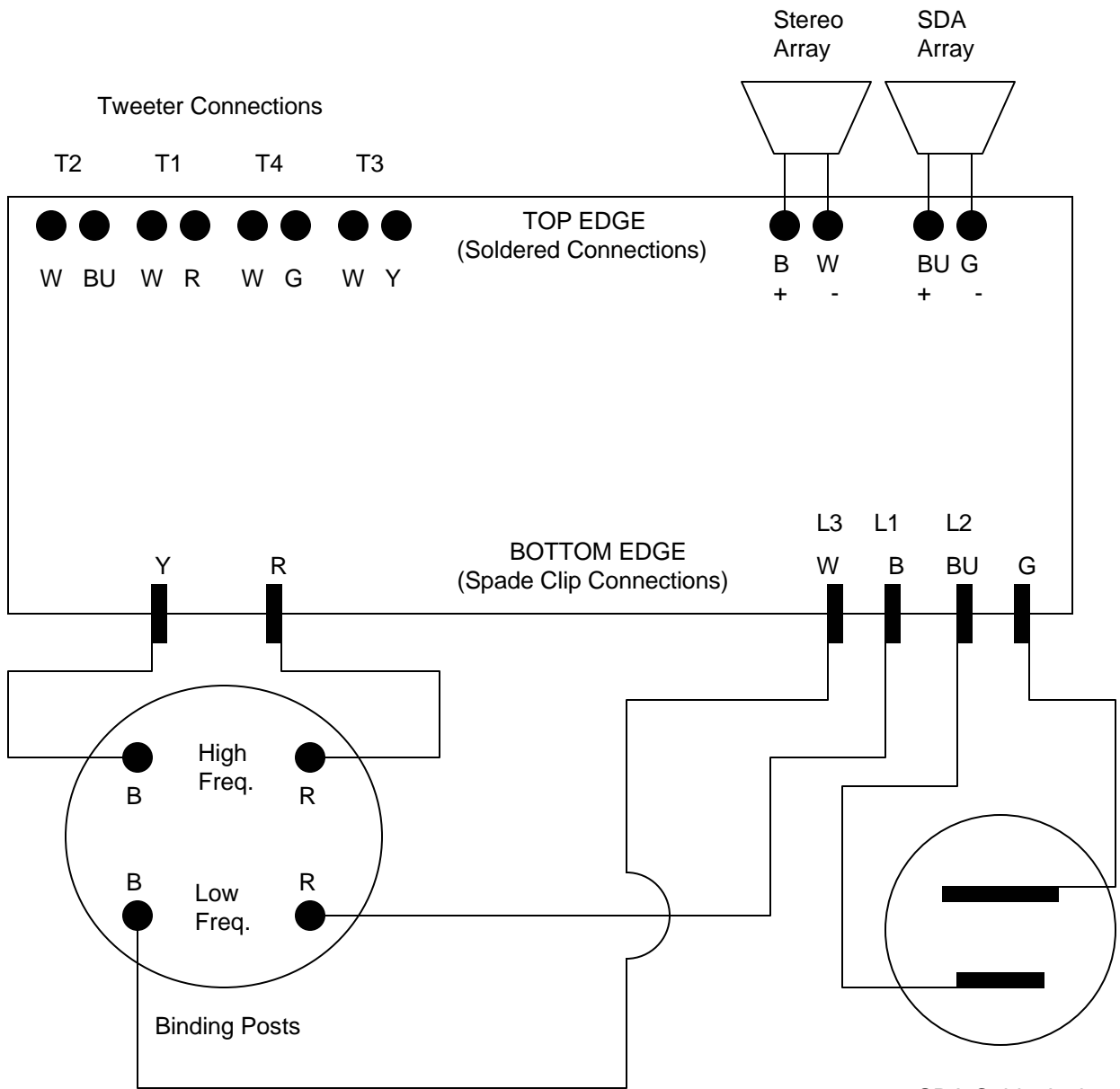

Wire Color Code:

- W = White
- R = Red
- G = Green
- B = Black
- BU = Blue
- Y = Yellow

SDA Cable Jack

This is the wiring diagram for the left SRS speaker. The right speaker has the blue wire connected to the top jack slot and the green wire connected to the bottom jack slot.

SDA SRS (1985) Crossover Wiring Diagram
R. F. Smith 07/07/2006

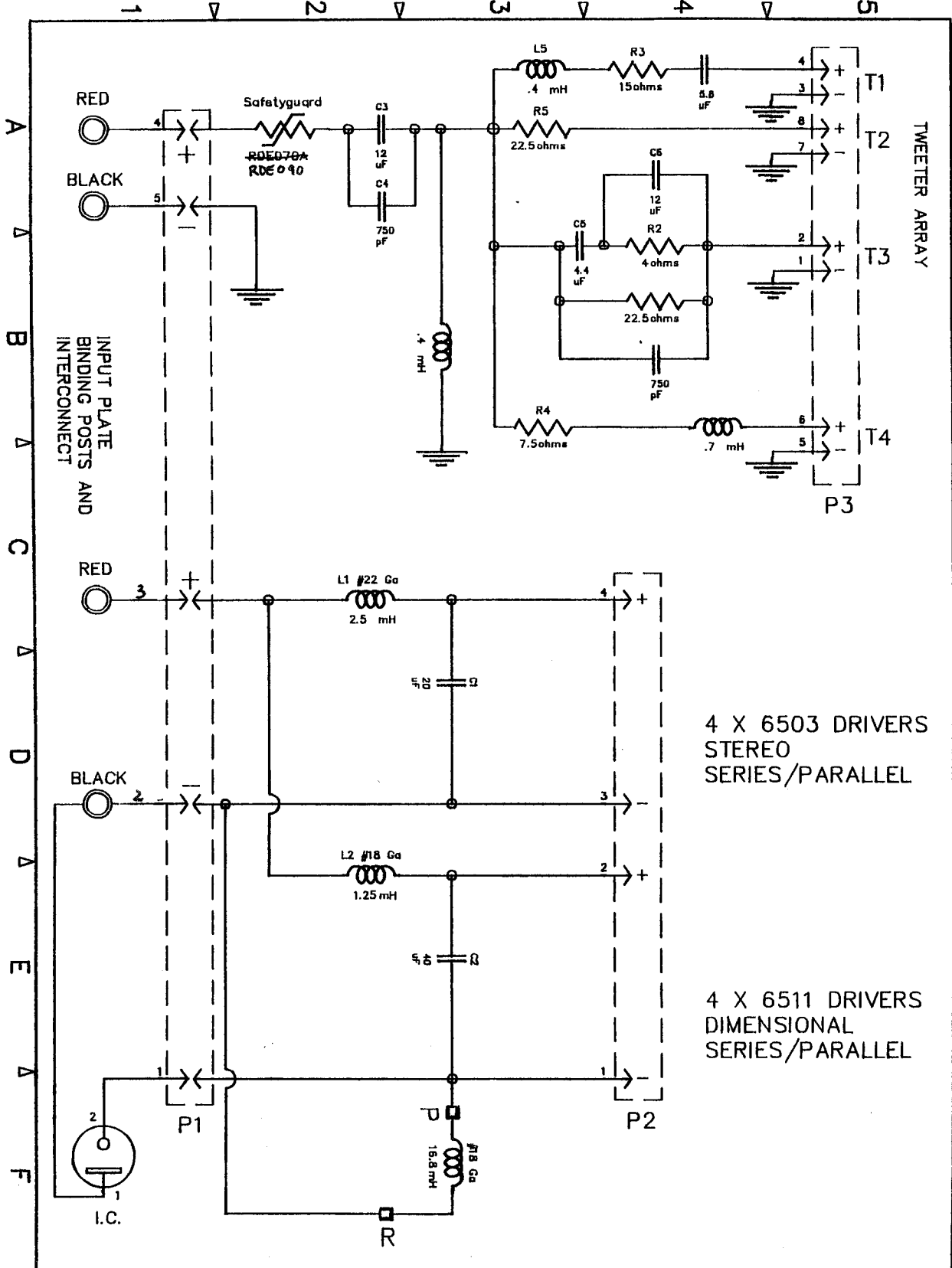

INPUT PLATE
BINDING POSTS AND
INTERCONNECT

TWEETER ARRAY

4 X 6503 DRIVERS
STEREO
SERIES/PARALLEL

4 X 6511 DRIVERS
DIMENSIONAL
SERIES/PARALLEL

PART DESCRIPTION: SCHEMATIC, SRS 1.2		DECIMAL: 2 PLC 3 PLC					
DRAWING TYPE: PRODUCT		DRAWING NUMBER: P0161002		+	+		
DRAWN BY: GLOTFELTY		PART NUMBER: -		FRACTIONAL:			
DATE: 05/24/88	VIEW NUMBER: 1	Q.A. APPROVAL: <i>[Signature]</i>		+	+		
polkaudio		FINAL APPROVAL: <i>[Signature]</i>		ANGULAR:			
		DATE: 5-25-88		+	+	DATE SYM	REVISION RECORD
				WHERE USED: AR200x-Bx		DR	CK

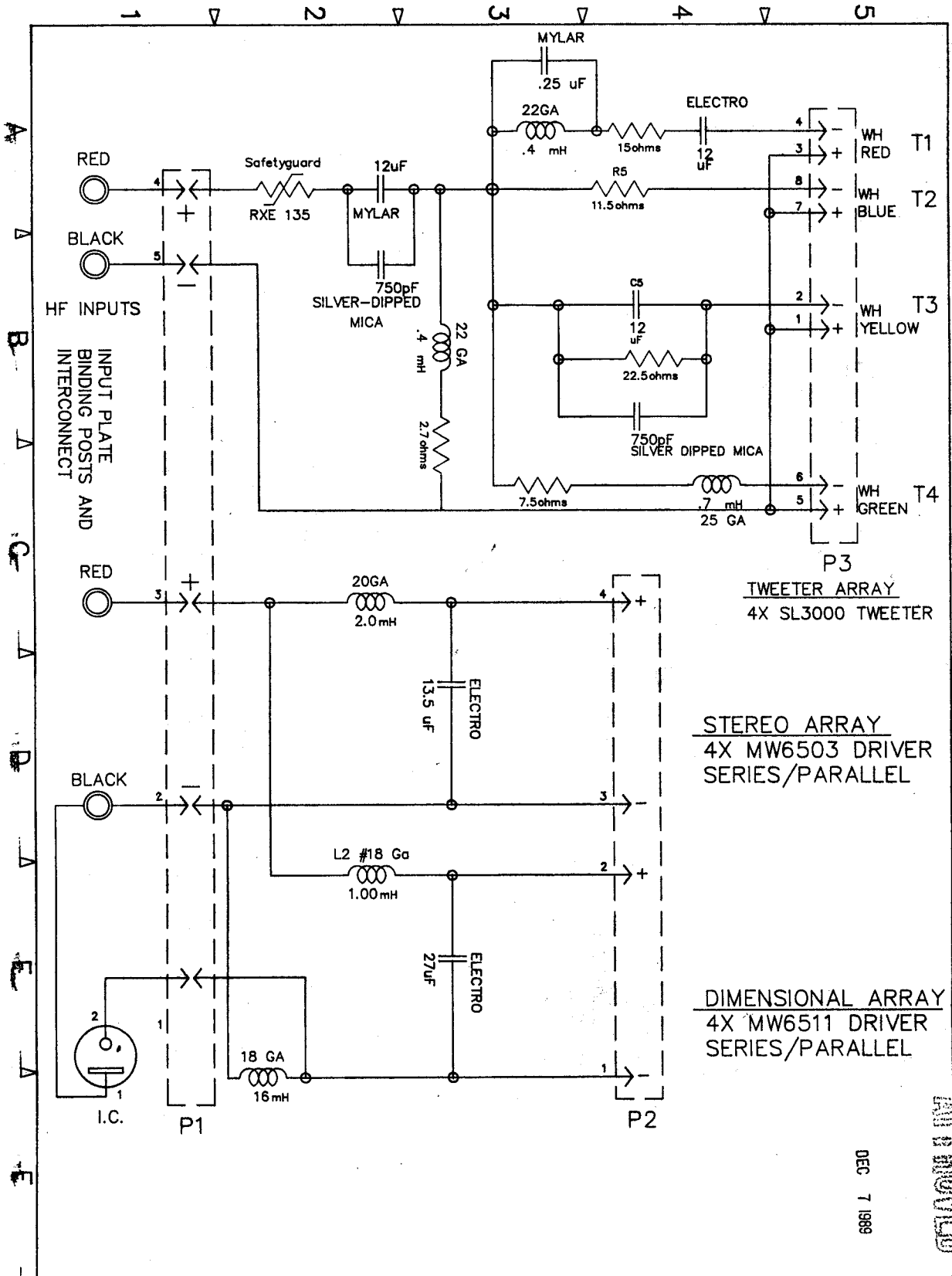

P3
TWEETER ARRAY
4X SL3000 TWEETER

STEREO ARRAY
4X MW6503 DRIVER
SERIES/PARALLEL

DIMENSIONAL ARRAY
4X MW6511 DRIVER
SERIES/PARALLEL

DEC 7 1989

APPROVED

PART DESCRIPTION: SCHEMATIC, SRS 1.2tl		DECIMAL: 2 PLC 3 PLC					
DRAWING TYPE: PRODUCT		DRAWING NUMBER: P0161003		+ -	+ -		
DRAWN BY: J.B.POLING		PART NUMBER: -		FRACTIONAL:			
DATE: 7/21/89	VIEW NUMBER: 1	Q.A. APPROVAL: <i>[Signature]</i>		DATE: 03/89		ANGULAR:	
polkaudio		FINAL APPROVAL: <i>[Signature]</i>		DATE: 8-3-89		DATE SYM	
				WHERE USED: AR20XX-DL/DR		REVISION RECORD	
						DR	CK

SRS 1.2t1 RIGHT CHANNEL

Ⓣ2 WHITE(-)
BLUE(+)

WHITE(-) Ⓣ1
RED(+)

Ⓣ4 WHITE(-)
GREEN(+)

WHITE(-) Ⓣ3
YELLOW(+)

STEREO DRIVERS

DIMENSIONAL DRIVERS

WHITE(-)
BLACK(+)
WHITE(-)
BLACK(+)
WHITE(-)
BLACK(+)
WHITE(-)
BLACK(+)
WHITE(-)
BLACK(+)
(WIRE MARKER)

GREEN(-)
BLUE(+)
GREEN(-)
BLUE(+)
GREEN(-)
BLUE(+)
(WIRE MARKER)
GREEN(-)
BLUE(+)
DRIVER OUTPUT
X-OVER INPUT

TWEETER OUTPUT

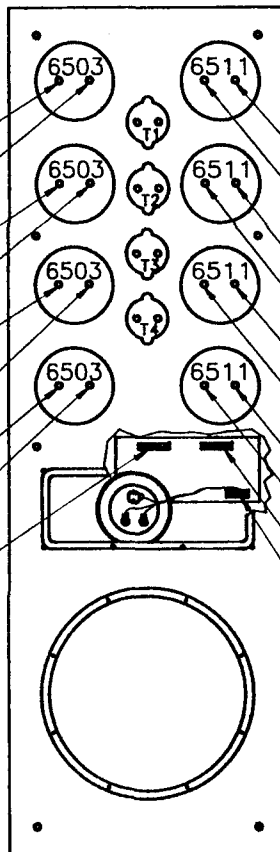

SEP 26 1989

APPROVED

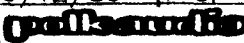
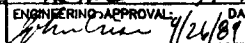
PART DESCRIPTION: SRS 1.2t1 WIRING DIAGRAM (RC)		DECIMAL: 2 PLG 3 PLG			
DRAWING TYPE: PROCESS	DRAWING NUMBER: M9101048	±.02 ±.015			
DRAWN BY: RICK SCHIMPF II	PART NUMBER: NA	FRACTIONAL: ±1/32			
DATE: 9/12/89	VIEW NUMBER: 1 OF 2	ANGULAR: ±0°30			
		DATE: 9/26/89	DATE SYM	REVISION RECORD	DR CK
		DATE: 9/26/89	WHERE USED: SRS 1.2 CAR ASSY		

SRS 1.2ti LEFT CHANNEL

Ⓣ1 WHITE(-)
RED(+)

WHITE(-) Ⓣ2
BLUE(+)

Ⓣ3 WHITE(-)
YELLOW(+)

WHITE(-) Ⓣ4
GREEN(+)

DIMENSIONAL
DRIVERS

STEREO
DRIVERS

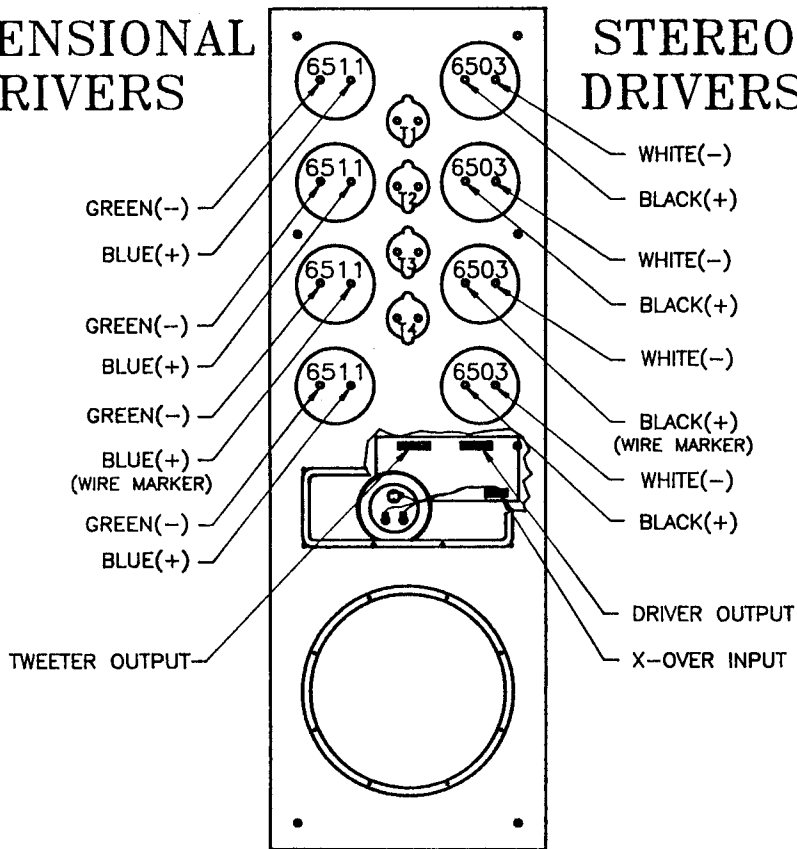

APPROVED
SEP 26 1989

PART DESCRIPTION: SRS 1.2ti WIRING DIAGRAM (LC)		DECIMAL: 2 PLC 3 PLC			
DRAWING TYPE: PROCESS	DRAWING NUMBER: M9101048	FRACTIONAL: ±.02 ±.015			
DRAWN BY: RICK SCHIMPF II	PART NUMBER: NA	±1/32			
DATE: 9/12/89	VIEW NUMBER: 2 of 2	DATE: 9/22/89	ANGULAR: ±0°30	DATE SYM	REVISION RECORD
				DR	CK
		WHERE USED: SRS 1.2 CAB ASSY			

Errata – SDA Compendium 2nd Edition

Page	Correction
xi	Section 4.5 starts on page 30 rather than page 31.
5	The first sentence of the last paragraph would have been better stated as “The first generation SDA’s used external fuses to protect the tweeters.”
6	Table 2.2 - The SL 1000 tweeter should have been mentioned in the driver complement of the SDA 2 and CRS.
7	Format error – Table 2.3 should not have been broken by text section.
8	Table 2.3 – The driver complement for the SDA 2A should read “ One 1 inch SL2000 silver coil dome tweeter and two 6-1/2 inch trilaminate polymer bass-midrange drivers”.
9	Format error - Table 2.4 should not have been broken by text section.
10	Table 2.4 – dimensions for SDA 1 C studio and SDA 2B studio were omitted.
11	Table 2.5 – Titles for last four specifications for 3.1TL are wrong. The titles should be “Nominal Impedance”, “Efficiency”, “Price” and “Dates of Manufacture”.
23	Caption for figure 3.13 should say "RD0198" rather than "RD0194".
64	Section 6.7.2, first paragraph, next to last sentence – the first “your” should be “you”.
67	Second paragraph, next to last sentence – the word “as” should have been deleted.